

Foreword

Before using CDI-SPD series photovoltaic water pump driver (hereinafter referred to as “the Product”), please read the manual carefully in order to ensure the proper use. Improper use may result in the equipment’s abnormal operation, malfunction, decrease of service life and even personal injury accident. Therefore, please do read the manual carefully before use and use the Product strictly according to the manual. The manual is a standard file which must be kept properly after reading for further repairing and maintenance of the Product in the future.

Besides the operating instructions, the manual also provides wiring diagram for your reference. If having difficulties or special requirements for usage of the Product, please feel free to contact our local offices or dealers or call our customer service center of the headquarters directly. We will offer dedicated service to you. We may change the contents of this Manual without a prior notice.

Please confirm the followings seriously when unpacking the Product:

1. Check if the Product is damaged, components and parts are damaged and drop and the body is collided in the transportation process.

2. Check if the rated value labeled on the nameplate of the Product accords with your order requirements and if the packaging box contains the machine that you order, product certificate, operation manual and warranty card.

We are strict in the manufacture, packaging and delivery. For any inspection omissions, please contact us or your supplier to solve the problem

Foreword

Chapter I Safety Operation and Attentions	- 1 -
1.1 Acceptance	- 1 -
1.2 Safety Operation Attentions	- 2 -
1.3 Safety mark of frequency converter	- 3 -
Chapter II Product Information	- 4 -
2.1 Nameplate Data and Naming Rule	- 4 -
2.2 Technical specifications	- 5 -
2.3 Product List	- 6 -
2.4 Appearance and Installation Dimension	- 8 -
2.5 Daily Maintenance and Repairing	- 8 -
Chapter III Installation and Wiring	- 15 -
3.1 Installation Site and Space	- 15 -
3.2 Standard Wiring	- 17 -
3.3 Earthing	- 22 -
Chapter IV Keyboard Operation and Running	- 23 -
4.1 Selection of Operation Mode	- 23 -
4.2 Precautions and inspection prior to test run	- 23 -
4.3 Keyboard Operation Method	- 24 -
Chapter V Commissioning Instructions	- 28 -
5.1 Check before operation	- 28 -
5.2 Commissioning	- 28 -
Chapter VI Functional Parameters Table	- 30 -
6.1 Group P0 - Basic Function	- 31 -
6.2 Group P1 - Motor Control Parameter	- 33 -
6.3 Group P2 - Input/Output Terminal Function	- 35 -
6.4 Group P3 - Programmable Function	- 43 -
6.5 Group P4 - PID Control and Communication Control	- 45 -
6.6 Group P5 - Keypad Display	- 47 -
6.7 Group P6 - Fault Display and Protection	- 50 -
6.8 Group P8 - Manufacturer Function	- 56 -
6.9 Group P9 - Monitoring Parameter	- 57 -
Chapter VII Parameters	59
7.1 Fault Display and Protection P6 Group	59
Chapter VIII RS-485 Communication	- 66 -
Chapter IX Fault Handling	- 74 -
Appendix 1 Recommended Configuration of Solar Cell Modules	- 80 -
Annex 2 AC/DC Switch Scheme of Frequency Converter	80

Chapter I Safety Operation and Attentions

Chapter I Safety Operation and Attentions

Please read this manual carefully before installation, operation, maintenance and inspection of the Product.

Please read this chapter before using the Product in order to ensure personal, equipment and property safety. Attentions related to safety operation in the manual are classified into “warning” and “cautions”.



Warning

: Potentially dangerous condition, which maybe cause severe body injuries or dead if relevant requirement is ignored.



Cautions

: Potentially dangerous condition, which maybe cause middle, light injuries or devedamage if relevant requirement is ignored, it also applies to unsafe operation.

1.1 Acceptance



The items in the table below must be inspected:

Items Inspected	Note
1. Is the model of frequency inverter consistent with order?	Check the Model indicated on the nameplate on one side of the frequency inverter.
2. Is there any damage to the components?	Survey the external appearance of the frequency inverter and make sure that no damage has occurred during
3. Are the components properly fastened?	Take off front cover of frequency inverter and use proper tools to inspect all visible components.
4. Is the user’s manual received?	User’s manual of frequency inverter

Please contact us or our agent if any of the items above fails to pass the acceptance.

Chapter I Safety Operation and Attentions

1.2 Safety Operation Attentions

 Warning	1. Installation and maintenance should be performed by professional only.
	2. Verify that rated voltage of the frequency inverter should conform with voltage level of AC power supply. Otherwise it shall cause hurt to human body or fire accident.
	3. Don't connect main circuit power with output terminals U, V and W. The connection will damage equipment, thus warranty card will be invalid.
	4. Don't connect input power until panel is well installed. Do not remove the cover when it is powered; otherwise, electric shock may occur.
	5. Don't touch high voltage terminal within frequency inverter under power-on status; otherwise, electric shock may occur.
	6. Maintain the frequency inverter after powering off it for at least 15 minutes because it has plenty of capacitance energies. At the moment, charging indicator light will be off or confirm the positive and negative Bus line voltages are under 36V; otherwise, electric shock can occur.
	7. Don't turn on or off line and connector when the circuit is powered on. Otherwise, personal injury may occur.
	8. Electronic components can be easily damaged by static electricity so please avoid touching them.
	9. This frequency inverter should not undergo voltage withstand test, which might result in damages to the semiconductor devices in it.
	10. Cover plate must be covered up before power on; otherwise, electric shock and explosion can occur.
	11. Never confuse the input and output terminals. Otherwise, explosion or damage to the property might occur.
	12. For frequency inverter of which storage period exceeds half year, please increase the input voltage gradually by using regulator, to prevent from electric shock and explosion.
	13. Don't operate the frequency inverter with wet hands; otherwise, electric shock may occur.
	14. All parts should be replaced by professional only. It is strictly prohibitive to remain stub or metal object in machine, to prevent from fire.
	15. After replaced control board, please perform relevant parameter setting before operation to prevent from damage of materials.
 Anti-static	1. If the motor is used for the first time or has been in leisure for a long time, remember to check its insulation first. It is advisable to use a 500V megger. Make sure the insulation resistance should not be less than 5 MΩ.
	2. Please consider the tolerance of mechanical device if it needs running above 50 Hz.
	3. In the regions with an altitude above 1,000 m, the heat dissipation effect of frequency inverter will be reduced due to thin air so it must be used with a reduced capacity. Reduce capacity by 1% for every 100 m after the altitude exceeds 1,000 m.
	4. Do not start or stop the frequency inverter with contactors. Otherwise, damage might occur to the equipment.
	5. Do not modify factory set value of frequency inverter without authorization, or damage might be caused.
 Cautions	

Chapter I Safety Operation and Attentions

1.3 Safety mark of frequency converter

Make sure to follow the warning marks which are pasted at the following position of the frequency converter.



- Make sure to read the Manual prior to installation and running to avoid an electric shock!
- Do NOT dismantle the cover plate when power is on or within 15min when power is cut off!
- Do NOT perform maintenance, inspection and wiring until the power supply at input/output side is cut off for over 15min and power indicator becomes off completely!

Chapter II Product Information

Chapter II Product Information

2.1 Nameplate Data and Naming Rule

Nameplate data: Take CDI-SPDG1R5S2 as an example:

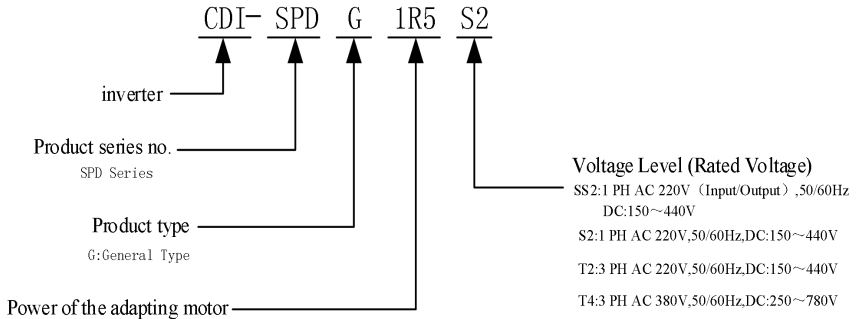
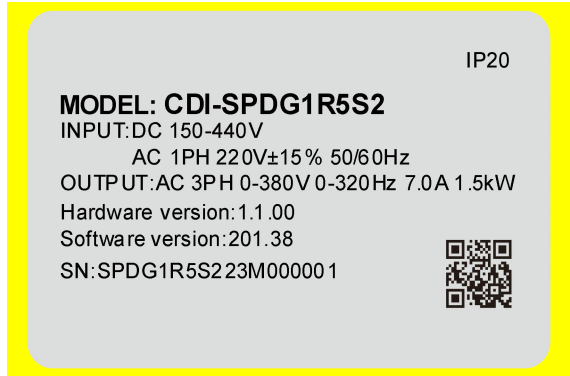

Chapter II Product Information

2.2 Technical specifications

Item		specification	
control	Control method	MPPT model, V/F model	
	Overload capacity	150% for 1min, 190% for 3s	
Configurat ion	Control power supply P24V	Maximum output current 300mA	
	Input terminal	SPD series (0.4kW~22k W)	4-way digital input terminal (DI1~DI4): DI1 supports forward rotation; DI2 supports reverse rotation, DI3 supports full water alarm function and DI4 supports Switch to general mode by force.
		SPD series (30kW and above)	5-way digital input terminal (DI2~DI6): DI2 supports reverse rotation; DI3 supports full water alarm function, DI4 supports Switch to general mode by force; DI5 and DI6 support setting of other functions.
running	Running method	Running via keyboard, terminal and communication	
	Timing control	can realize the inverter reaches a given time and automatically stops	
communication		SPD series(0.4kW~22kW)the control board no RS485communication terminal , requires an external communication expansion card, SPDseries(30kW and above) control board directly has an RS485 communication interface and supports standard MODBUS-RTU protocol	
display	Running information	Output current, output voltage, bus voltage, output frequency, etc.	
	Fault information	In running status of fault protection, the information of each fault includes the frequency, current, busbar voltage, input/output terminal status at fault condition.	
Protect	Inverter protection	Overcurrent, overvoltage, undervoltage, overheating, overload, phase loss protection, external fault protection, etc.	
	Inverter alarm	Sleep alarm, low-frequency alarm, full water alarm and interruption alarm.	
Environm en	Environment Ambient temperature	-10℃~40℃	
	Storage temperature	-20℃~65℃	
	Ambient humidity	MAX 90%RH(no condensation)	
	Height / vibration	1000m or less, 5.9m / s ² (= 0.6g) or less	
	Application	No corrosive gas, flammable gas, oil mist or dust and other	
Cooling method		Forced air cooling	

Chapter II Product Information

2.3 Product List

Model of Frequency Inverter	Rated Input Current (A)	Rated Output Current (A)	Adaptive Motor (kW)	net weight (kg)	gross weight (kg)
CDI-SPDG0R4SS2	9.5	5.0	0.4	0.6	1.0
CDI-SPDG0R7SS2	15.7	7.0	0.7	1.2	1.48
CDI-SPDG1R5SS2	27.0	10.0	1.5	1.2	1.59
CDI-SPDG2R2SS2	29.4	14.0	2.2	2.5	2.9
CDI-SPDG4R0SS2	32.8	17.0	4.0	2.5	3.16
CDI-SPDG5R5SS2	51.5	25.0	5.5	4.0	4.83
CDI-SPDG0R4S2	6.5	3.0	0.4	0.6	1.0
CDI-SPDG0R7S2	9.5	5.0	0.7	0.6	1.09
CDI-SPDG1R5S2	15.7	7.0	1.5	1.3	1.5
CDI-SPDG2R2S2	27.0	10.0	2.2	1.3	1.52
CDI-SPDG4R0S2	32.8	17.0	4.0	2.5	2.9
CDI-SPDG5R5S2	51.5	25.0	5.5	—	—
CDI-SPDG4R0T2	18.5	17.0	4.0	—	—
CDI-SPDG5R5T2	26.0	25.0	5.5	—	—
CDI-SPDG0R7T4	3.4	3.0	0.7	0.9	1.18
CDI-SPDG1R5T4	5.0	4.5	1.5	0.9	1.18
CDI-SPDG2R2T4	6.8	6.0	2.2	1.2	1.48
CDI-SPDG4R0T4	10.5	9.5	4.0	1.2	1.59
CDI-SPDG5R5T4	15.5	13.0	5.5	2.5	2.9
CDI-SPDG7R5T4	20.5	17.0	7.5	2.5	3.16
CDI-SPDG011T4	26	25.0	11	4	4.83
CDI-SPDG015T4	35	32.0	15	4	4.93
CDI-SPDG018.5T4	38.5	37.0	18.5	7	7.365
CDI-SPDG022T4	46.5	45.0	22	7	7.625
CDI-SPDG030T4	62	60.0	30	15	15.5
CDI-SPDG037T4	76	75.0	37	15	15.5
CDI-SPDG045T4	92	90.0	45	25	30.5
CDI-SPDG055T4	113	110.0	55	25	31
CDI-SPDG075T4	157	152.0	75	36	42
CDI-SPDG090T4	180	176.0	90	36	43
CDI-SPDG110T4	214	210.0	110	36	44

Chapter II Product Information

Model of Frequency Inverter	Rated Input Current (A)	Rated Output Current (A)	Adaptive Motor (kW)	net weight (kg)	gross weight (kg)
CDI-SPDG132T4	256	253	132	75	82.5
CDI-SPDG160T4	305	300	160	75	86
CDI-SPDG185T4	344	340	185	75	87
CDI-SPDG200T4	383	380	200	160	180
CDI-SPDG220T4	425	420	220	160	180
CDI-SPDG250T4	484	480	250	180	205
CDI-SPDG280T4	543	540	280	180	205
CDI-SPDG315T4	605	600	315	180	205
CDI-SPDG355T4	683	680	355	200	232
CDI-SPDG375T4	714	710	375	200	232
CDI-SPDG400T4	753	750	400	207	232

Ordering instruction:

Please specify the corresponding model and specification of the products when placing an order. For any special requirements, please contact us for negotiation.

Chapter II Product Information

2.4 Appearance and Installation Dimension

Model1

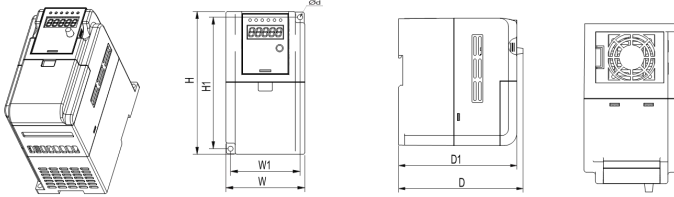

Model	W	W1	H	H1	D	D1	Ø d
CDI - SPDG0R4SS2	84	74	152	140	148.4	141	5.5
CDI - SPDG0R4S2							
CDI - SPDG0R7S2							
CDI - SPDG0R7T4	84	77	152	144	148.4	141	4.5
CDI - SPDG1R5T4							

Unit:mm

Main Circuit Wiring Diagram :



Note :

1. Plastic shell
2. The ordering of the terminals is subject to material object

Model2

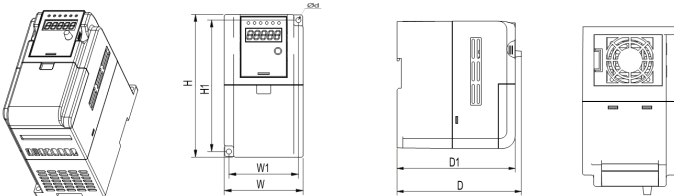

Model	W	W1	H	H1	D	D1	Ø d
CDI - SPDG0R7SS2	105	95	165	153	161.4	154	5.5
CDI - SPDG1R5SS2							
CDI - SPDG1R5S2							
CDI - SPDG2R2S2	105	95	165	155	161.4	154	4.5
CDI - SPDG2R2T4							
CDI - SPDG4R0T4							

Unit:mm

Main Circuit Wiring Diagram :



Note :

1. Plastic shell
2. The ordering of the terminals is subject to material object

Chapter II Product Information

Model3

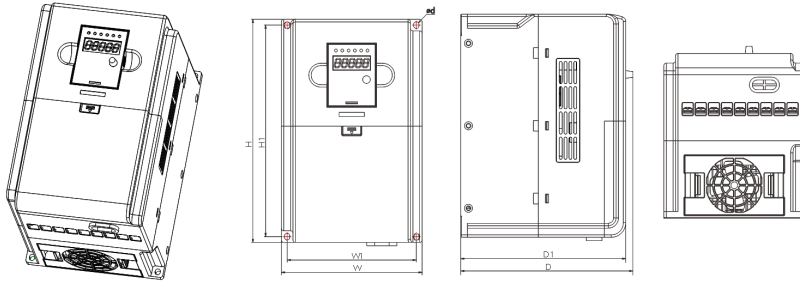

Model	W	W1	H	H1	D	D1	φ d
CDI - SPDG2R2SS2	145	133	230	218	177.4	170	5.5
CDI - SPDG4R0SS2							
CDI - SPDG4R0S2							
CDI - SPDG4R0T2							
CDI - SPDG5R5T4							
CDI - SPDG7R5T4							

Unit:mm

Main Circuit Wiring Diagram :

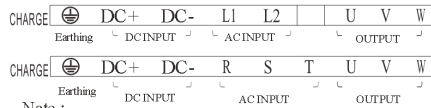

Note :

1. Plastic shell
2. The ordering of the terminals is subject to material object

Model4

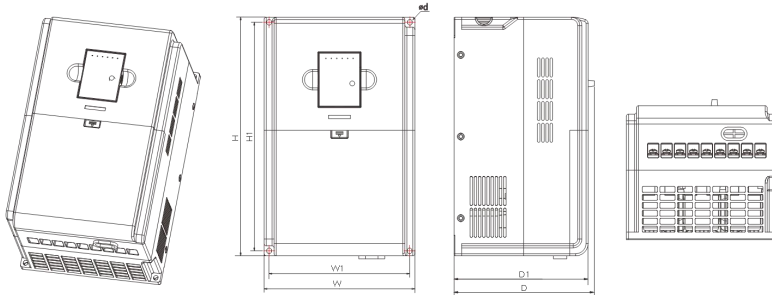

Model	W	W1	H	H1	D	D1	φ d
CDI - SPDG5R5SS2	180	168	285	273	167.4	180	5.5
CDI - SPDG5R5S2							
CDI - SPDG5R5T2							
CDI - SPDG011T4							
CDI - SPDG015T4							

Unit:mm

Main Circuit Wiring Diagram :

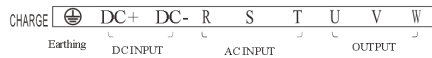

Note :

1. Plastic shell
2. The ordering of the terminals is subject to material object

Chapter II Product Information

Model 5

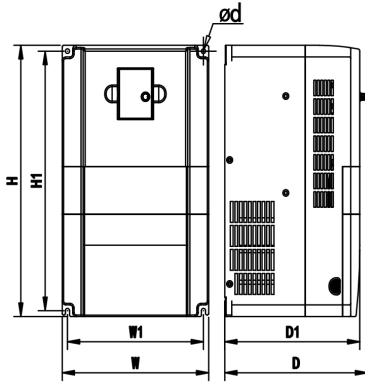

Model	W	W1	H	H1	D	D1	ød
CDI-SPDG018.5T4	210	198	350	335	205	193.5	6
CDI-SPDG022T4							

Unit:mm

Main Circuit Wiring Diagram

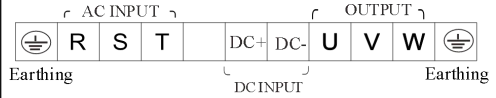

Note:

The ordering of the terminals is subject to material object

Model 6

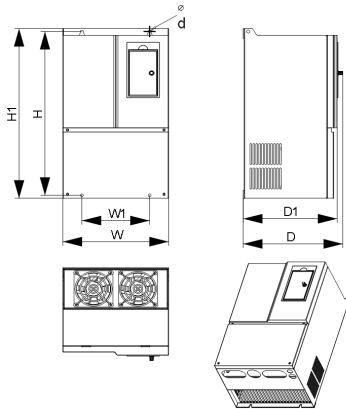

Model	W	W1	H	H1	D	D1	ød
CDI-SPDG030T4	250	160	430	415	235.5	222	7
CDI-SPDG037T4							

Unit:mm

Main Circuit Wiring Diagram



Note:

The ordering of the terminals is subject to material object

Chapter II Product Information

Model7

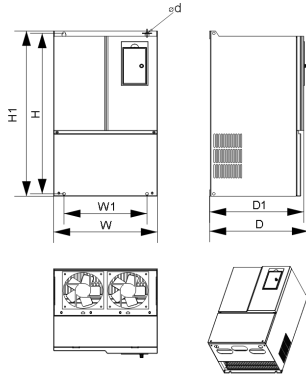

Model	W	W1	H	H1	D	D1	ø d
CDI-SPDG045T4	300	240	530	515	285.5	272	9
CDI-SPDG055T4							

Unit:mm

Main Circuit Wiring Diagram :



Note :

The ordering of the terminals is subject to material object

Model8

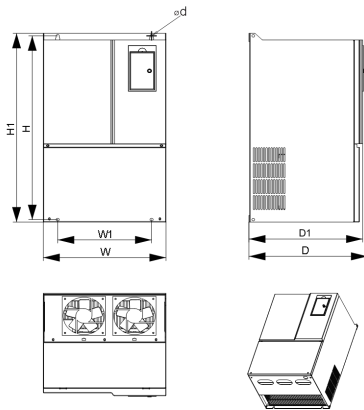

Model	W	W1	H	H1	D	D1	ø d
CDI-SPDG075T4	340	260	580	565	328.5	315	9
CDI-SPDG090T4							
CDI-SPDG110T4							

Unit:mm

R
Main Circuit Wiring Diagram :



Note :

The ordering of the terminals is subject to material object

Chapter II Product Information

Model 9

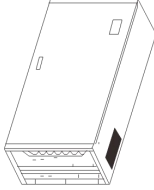
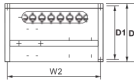
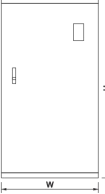
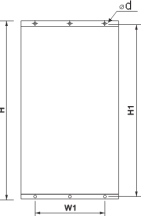

Model	W	W1	W2	H	H1	D	D1	ed
CDI-SPDG132T4								
CDI-SPDG160T4	400	300	365	940	910	367	336	13
CDI-SPDG185T4								

Unit:mm

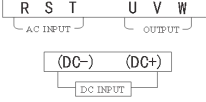

Note:
The ordering of the terminals is subject to material object

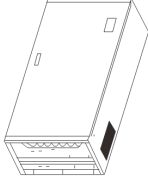
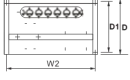
Model 10

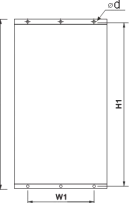

Model	W	W1	W2	H	H1	D	D1	ed
CDI-SPDG200T4	514	400	504	1235	1200	400	360	14
CDI-SPDG220T4								

Unit:mm

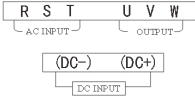

Note:
The ordering of the terminals is subject to material object

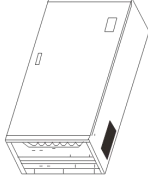
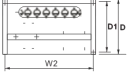
Model 11

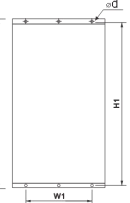
Model	W	W1	W2	H	H1	D	D1	ed
CDI-SPDG250T4								
CDI-SPDG280T4	545	400	504	1345	1310	400	360	14
CDI-SPDG315T4								
CDI-SPDG355T4								
CDI-SPDG375T4	545	400	504	1450	1415	400	360	14
CDI-SPDG400T4								

Unit:mm

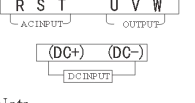

Note:
The ordering of the terminals is subject to material object

2.5 Daily Maintenance and Repairing

(1) Daily maintenance

The influence such as environmental temperature, humidity, dust and vibration may result in aging of the internal components of frequency inverter, which should cause potential fault of frequency inverter or reduction of its service life. Therefore, it is necessary to perform daily maintenance and regular inspection with the frequency inverter.

Daily inspection item:

- A Check if the sound of motor running has any abnormal change.
- B Check if there is any vibration in motor running.
- C Check if the installation environment of frequency inverter is changed.
- D Check if the cooling fan of frequency inverter works normally.

Daily cleaning:

- A Keep frequency inverter always clean and tidy.
- B Clean surface dust on the frequency inverter effectively in order to prevent dust from entering the frequency inverter, especially metal dust.
- C Clean oil dirt of frequency inverter's cooling fan effectively.

(2) Regular inspection

Please inspect places that can be hardly inspected regularly.

Regular inspection item:

- A Inspect and clean air flue regularly.
- B Inspect if the screw is loose.
- C Inspect if the frequency inverter is corroded.
- D Inspect if there is arc on surface connecting terminal.

(3) Replacement of vulnerable parts

The vulnerable parts of the frequency inverter include cooling fan and filter electrolytic capacitor, the service life of which closely depend on operating environment and maintenance condition.

Users can confirm replacement period according to running time.

A Cooling fan

Possible damage reasons: Bearing abrasion and blade aging.

Judgment standard: Confirm if the fan blade has cracks and abnormal vibration sound when starting.

B Filter electrolytic capacitor

Possible damage reasons: Input power with low quality, high environment temperature, frequent load modulation and electrolyte aging.

Judgment standard: Confirm if the liquid leaks and safety valve has protruded; measurement of electrostatic capacity and insulation resistance.

(4) Storage of frequency inverter

After purchased the device, please pay attention to following points while

Chapter II Product Information

storing it:

A Please store it in original package as much as possible.

B Long term storage should cause aging of electrolytic capacitor. Make sure to electrify it once every half a year for at least 5 hours and to raise voltage to rated value slowly via voltage regulator.

(5) Warranty of frequency inverter

Maintenance free is limited to the frequency inverter only.

We provide life-long paid service for our products, whenever and wherever they are used.

We bear the responsibilities of repair, replacement and return at most for the product once quality or product accident happens. If users need more responsibility compensation warranties, please place insurance at the property insurance company in advance.

Warranty service should be effective in 18 months after bar code date.

For fault caused in following reasons, a pay-needed maintenanceservice only is available even warranty term is effective:

A Faults caused by incorrect operation (subject to user's manual) or unauthorized repair and refitting.

B Problems caused by using the frequency inverter beyond requirements of standard and specification.

C Damage caused by accidental drop and improper handling after purchase.

D Aging or fault caused by severe environment.

E Damage caused by natural disasters such as earthquake, fire disaster, wind, lightning stroke, abnormal voltage or reasons happening together with disasters.

F Damage in the transportation process (Notes: Transportation mode is designated by user of themselves. We could assist agent to conduct transfer of goods).

G When brand, trademark, serial number and nameplate marked by manufacturers are damaged or can't be recognized.

H Failure to pay off fund according to purchase contract.

I Failure to describe actual conditions relating to installation, wiring, operation, maintenance, or other condition to the Company.

For the repair, replacement and return services, customers need to send the product back to us. We will provide the corresponding service after confirming the responsible party.

We still have the ownership of the product for which the buyer doesn't pay off the price or pay the residual fund in time. In such case, we do not undertake the above responsibilities and the buyer cannot propose any disagreement.

All relevant service fees shall be calculated in accordance with the identical standards of the factory. In the event that an agreement or a contract exists, its priority shall be performed.

Chapter III Installation and Wiring

3.1 Installation Site and Space

Installation site:

 Warning	1. Avoid direct sunlight and outdoor direct use.
	2. Don't use it under corrosive gas and liquid environment.
	3. Don't use it under oil fog and splashing water environment.
	4. Don't use it under salt fog environment.
	5. Don't use it under raining and moist environment.
	6. Please equip the unit with filters device if metal dust or fiber wadding existing in air.
	7. Avoid power noise, such as electric welding machine and high-power electrical equipment, which can impact operation of the equipment.
	8. Radioactive materials can influence use of the Product.
	9. Avoid flammable materials, thinner and solvent.
Environment	Environment temperature: -10°C~+40°C
	Storage temperature: -20°C~+65°C
	Environment humidity: 90% RH at maximum (noncondensing)
	Height: Under 1,000 m. Reduce capacity by 1% for every 100 m after the altitude exceeds 1,000 m.
	Vibration: No greater than 5.9 m/s ² (0.6 g) at maximum.
	Installation direction: Please install the product vertically in order not to affect the heat dissipation effect of frequency inverter.

For sound performance and long service life, the frequency inverter shall be installed according to the above installation environment suggestions to prevent damages.

Chapter III Installation and Wiring

Installation space:

When frequency inverters are installed vertically, enough heat dissipation space shall be reserved in order to ensure effective cooling.

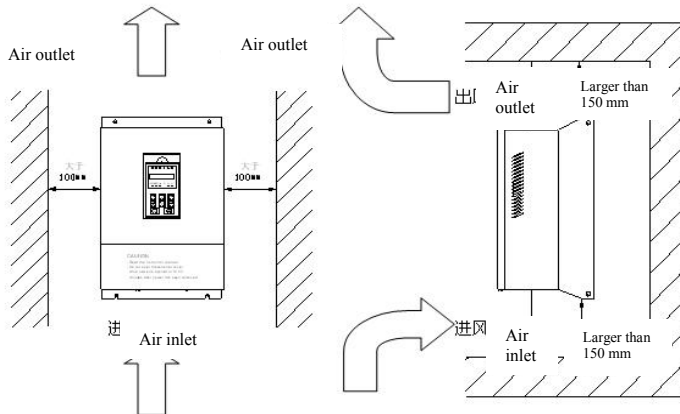

Installation Space of Frequency Inverter

 Cautions	1. Necessary clearance for open-frame type (IP00) and enclosed wall-mounted type (IP20) is the same at the top/bottom and both sides.
	2. Air temperature at the permitted inlet of frequency inverter: $-10^{\circ}\text{C}\sim+40^{\circ}\text{C}$.
	3. Enough heat dissipation space shall be reserved in the upper and lower areas in order to ensure smooth air intake and emission of frequency inverter.
	4. Don't let foreign objects fall inside air duct during installation lest fan damage.
	5. Add filtering device at air intake when silk fibers fly or it is very dusty.

Chapter III Installation and Wiring

3.2 Standard Wiring

See the standard wiring diagram of the main circuit and control circuit of the Product in the figure below:

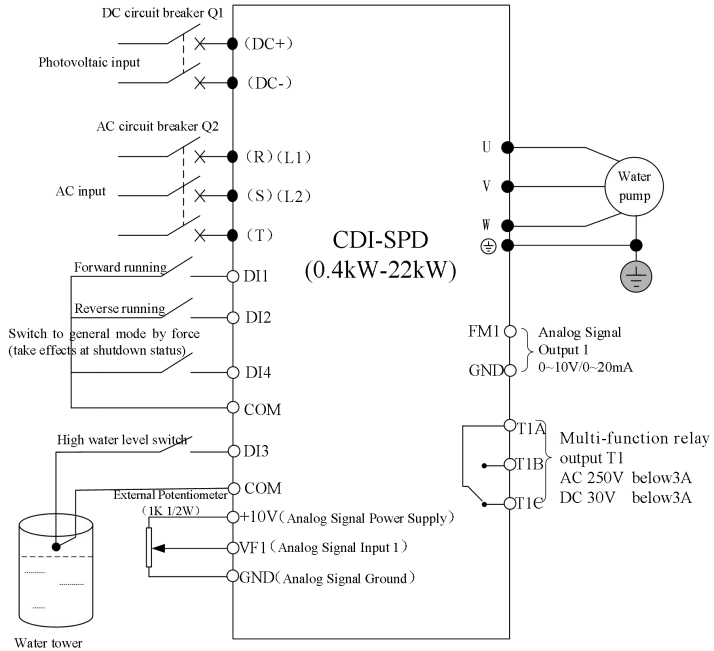

Chapter III Installation and Wiring

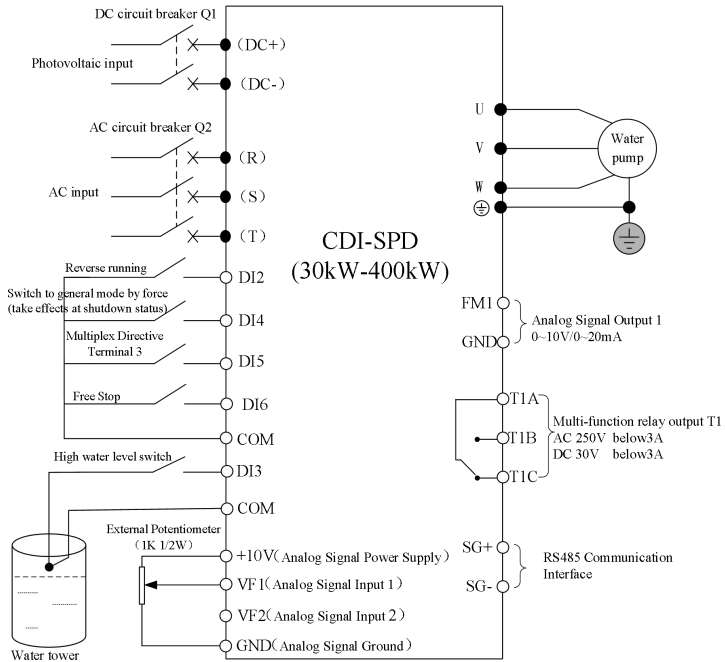

Cautions

1. DC circuit breaker Q1 must be installed as the protection switch of PV DC input.
2. Frequency inverter must not be in AC and DC connection at the same time. If it requires AC/DC connection at the same time, switching control circuit shall be configured externally.
3. Special PV combiner boxes shall be used for the parallel connection of components.
4. When PV cell module is more than 10 m from frequency inverter, Type II lightning arrester shall be configured at DC input end.
5. When water pump is more than 50 m from frequency inverter, it is suggested to select output reactor.
6. The frequency converter is running via keyboard by default. Please set the parameters in strict accordance with the guide steps in Chapter 4.
7. Tighten terminal screws according to the specified tightening torque.
8. Make sure the earthing terminals have been earthed before connecting the main circuit.
9. Terminal arrangement sequence shall be subject to physical objects.

Chapter III Installation and Wiring

3.2.1 Description of the terminals of frequency inverter

Description of the Main Circuit Terminals of Frequency Inverter:

Identification	Name	Function Description
R, S, T (L1, L2)	AC input	3-phase (single-phase) AC input terminal, connected to power grid
DC+, DC-	PV DC input	Input terminal of PV cell panel
U, V, W	Output of frequency Inverter	3-phase (single-phase) AC output terminal, generally connected to the motor of water pump
	Safe protection earthing	Safe protection earthing terminal; each machine must be earthed reliably

Description for -SS2 single-phase output models

1) Generally, the output terminals U and W of the inverter connect to the phase cables of the single-phase motor.

2) If the single-phase pump cannot be started, the two-phase control method must be used, and the start-up and running capacitors (if any) of the motor must be removed. The figure below shows the internal wiring of the common single-phase motor. In the figure, L1, L2, C1, and C2 indicate the running winding, start-up winding, running capacitor, and start-up capacitor. When the motor speed exceeds 75% of the rated speed, the start-up capacitor is switched off.

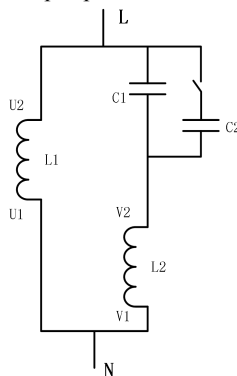

Internal wiring of the single-phase motor winding after removing the starting and running capacitor:

Chapter III Installation and Wiring

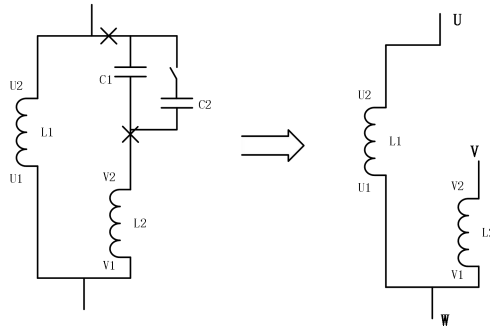

U1 and V1 are the common terminals of the windings. Connect them to the output terminal W of the solar pumping inverter. Connect U2 to the output terminal U of the inverter. Connect V2 to the output terminal V of the inverter. (Note: Use the screws equipped with the inverter.)

Description of the Control Circuit Terminals of Frequency Inverter:

Classification	Terminal	Name	Function Description
Digital quantity input	DI1	Digital input 1	The control panel is fitted with terminal as standard configuration. For details of functions, please refer to P2.0.00~P2.0.05
	DI2	Digital input 2	
	DI3	Digital input 3	
	DI4	Digital input 4	
	DI5	Digital input 5	
	DI6	Digital input 6	
T1 relay	T1A	Multi-function relay output T1	TA-TB is normally on TTA-TC is normally off Driving capability: AC 250 V below 3 A DC 30 V below 3 A
	T1B		
	T1C		
+24 V power supply	COM	24 V power output	Provide DC 24 V power voltage to the external. Driving capability: Maximum output current 300 mA
	+24V		

Chapter III Installation and Wiring

3.2.2 Wiring reference for the main circuit and control circuit is as shown in the table below

Model of Frequency Inverter	Wire Gauge of Main Circuit (mm ²)		Wire Gauge of Main Circuit (mm ²)
	DC+/DC-, R/S/T, U/V/W	⊕ PE	
CDI-SPDG0R4SS2	2.5	2.5	1.0
CDI-SPDG0R7SS2	2.5	2.5	1.0
CDI-SPDG1R5SS2	4	4	1.0
CDI-SPDG2R2SS2	4	4	1.0
CDI-SPDG4R0SS2	6	6	1.0
CDI-SPDG5R5SS2	6	6	1.0
CDI-SPDG0R4S2	2.5	2.5	1.0
CDI-SPDG0R7S2	2.5	2.5	1.0
CDI-SPDG1R5S2	2.5	2.5	1.0
CDI-SPDG2R2S2	4	4	1.0
CDI-SPDG4R0S2	6	6	1.0
CDI-SPDG5R5S2	6	6	1.0
CDI-SPDG4R0T2	6	6	1.0
CDI-SPDG5R5T2	6	6	1.0
CDI-SPDG0R7T4	2.5	2.5	1.0
CDI-SPDG1R5T4	2.5	2.5	1.0
CDI-SPDG2R2T4	2.5	2.5	1.0
CDI-SPDG4R0T4	4	4	1.0
CDI-SPDG5R5T4	4	4	1.0
CDI-SPDG7R5T4	6	6	1.0
CDI-SPDG011T4	6	6	1.0
CDI-SPDG015T4	10	10	1.0
CDI-SPDG018.5T4	16	16	1.0
CDI-SPDG022T4	16	16	1.0
CDI-SPDG030T4	25	16	1.5
CDI-SPDG037T4	25	16	1.5
CDI-SPDG045T4	35	16	1.5
CDI-SPDG055T4	35	16	1.5
CDI-SPDG075T4	50	25	1.5
CDI-SPDG090T4	70	35	1.5
CDI-SPDG110T4	120	60	1.5
CDI-SPDG132T4	150	75	1.5
CDI-SPDG160T4	185	92.5	1.5
CDI-SPDG185T4	185	92.5	1.5
CDI-SPDG200T4	300	150	1.5

Chapter III Installation and Wiring

Model of Frequency Inverter	Wire Gauge of Main Circuit (mm ²)		Wire Gauge of Main Circuit (mm ²)
	DC+/DC-, R/S/T, U/V/W	PE	
CDI-SPDG220T4	300	150	1.5
CDI-SPDG250T4	370	185	1.5
CDI-SPDG280T4	370	185	1.5
CDI-SPDG315T4	450	225	1.5
CDI-SPDG355T4	450	225	1.5
CDI-SPDG375T4	600	300	1.5
CDI-SPDG400T4	600	300	1.5

3.3 Earthing

1. Earthing resistance:
200 V level: 100 Ω or below
400 V level: 10 Ω or below

2. Don't earth frequency Inverter, electric welder, motor or other large-current electrical equipment commonly. Make sure all earth wires inside conduit are laid separately from the leads of large-current electrical equipment.

3. Use earth wires up to the specified standard and shorten their length as much as possible.

4. When several frequency Inverters are used in a row, please earth the device as shown in Fig. (a) and Don't make earth wires form a circuit as shown in Fig. (c).

5. Frequency Inverters and motors shall be earthed according to the connections given in Fig. (d).

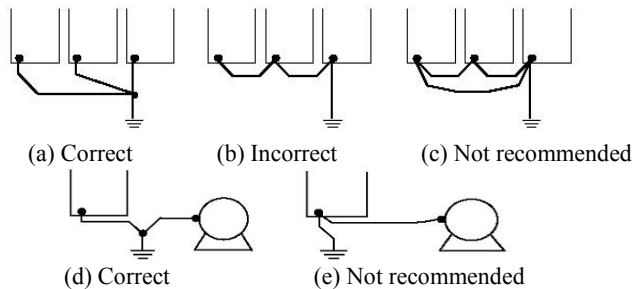

6. Wiring inspection:

Inspect the following items after installation and wiring are completed.

- A. Check if the wiring is correct.
- B Check if there is broken wire residues or screws left inside the device.
- C Check if the screws are tightened firmly.
- D Check if the naked leads on terminal contact with other terminals



Chapter IV Keyboard Operation and Running

Chapter IV Keyboard Operation and Running

4.1 Selection of Operation Mode

The Product is provided with three control modes, including keyboard running, terminal running, and communication operation. Users can select corresponding control mode according to field environment and working needs. See P0 for specific selections.

4.2 Precautions and inspection prior to test run

 Danger	1. Don't turn power on until the front cover is installed and Don't remove the outer cover when power is on; otherwise, electric shock will be caused.
	2. Don't get close to frequency inverter or load when restart is selected, as the device will restart suddenly after it is just stopped. (Even if frequency inverter restarts, its mechanical system can ensure personal safety). Otherwise, personal injuries will be caused.
	3. As stop button will become not working after function setting, a separate emergency stop button should be installed; otherwise, personal injuries will be caused.
 Cautions	1. Don't touch the radiator or resistor since it is hot; otherwise, burns will be caused.
	2. As low-speed running can easily become high-speed running, confirm the safe working range of motor and mechanical equipment before running; otherwise, personal injuries and equipment damages may be caused.
	3. If necessary, install a band-type brake separately; otherwise, person injuries will be caused.
	4. Don't change wiring during operation; otherwise, the equipment or frequency inverter will be damaged.

In order to ensure safety, mechanical coupler shall be unhooked before initial running, so that the motor can separate from mechanical equipment. If the motor and mechanical equipment are coupled before the initial running, special attention should be paid in to prevent possible dangers. Inspect the following contents before test run:

- A Whether leads and terminals are connected correctly.
- B Whether there is lead residues that may cause short circuit.
- C Whether screw terminals are tightened firmly.
- D Whether the motor is installed firmly.

Chapter IV Keyboard Operation and Running

4.3 Keyboard Operation Method

4.3.1 Keys and functions of keyboard

(1) Keys and functions of keyboard



Name		Description
Status indicator lamp	FWD	The frequency converter is under forward/reverse rotation when indicator is on/off
	RUN	frequency inverter is running when it is on
	TUNE	Keyboard start: TUNE light normally off Auto start and terminal start: TUNE lamp flickers Communication enabling: TUNE lamp is normally on
Unit indicator lamp	V	Indicate voltage value
	A	Indicate current value
	Hz	Indicate frequency value
	V-%-A	Indicate percentage
	A-RPM-Hz	Indicate rotating speed
Key area	MODE	Switch display mode; cancel data modification
	ENTER	Reads and stores parameter when it is set.
	▲	Function code selection: Add/subtract data setting; when keyboard frequency is given, add/subtract data setting
	▼	
	»»	Monitoring mode, rolling display of data; move data modification position when selecting and setting parameters
		Potentiometer, adjust frequency
	JOG	Multi-functional key
	RUN	Running key
STOP/RESET	Stop and reset key	

Chapter IV Keyboard Operation and Running

(2) Keyboard 1:



Keyboard dimensions: 65 mm*50 mm

Keyboard seat installation dimensions: 77.5*59 mm

Keyboard seat dimensions: 83.5*65 mm

Keyboard 1 is the standard configuration for frequency inverter model 1~5

(3) Keyboard 2:



Keyboard dimensions: 117 mm*68 mm

Keyboard seat installation dimensions:136*72mm

Keyboard seat dimensions:142*78mm

Keyboard 2 is the standard configuration for frequency inverter model 6 and above

Chapter IV Keyboard Operation and Running

4.3.2 Methods to view/give parameters (with digital keyboard)

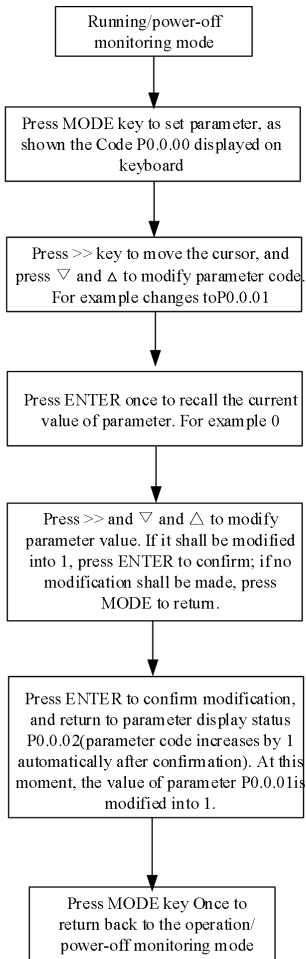

For example, the example below is listed by changing the acceleration time parameter P0.0.11 from 010.0 to 016.0.

1	50.00	The set display frequency is 50.00 Hz. Press MODE key to enter parameter setting
2	P0.0.00	Display parameter P0.0.00, and at the same time, the pointer blinks at the last data bit "0". Press ▾ and ▲ to select the functional code to set, and press >> to move the data bit.
3	P0.0.11	Press >>, ▲ ▾ key to modify the display value as P0.0.11 and then press ENTER key
4	010.0	Check whether default parameter is 010.0 and the pointer stays at the final data bit "0"
5	016.0	Press >>, ▲ ▾ key to modify the display value as 016.0 and then press ENTER key
6	P0.0.12	Save data and write in 016.0, the parameter shows that acceleration time is changed from 010.0 to 016.0 and the returned parameter displays P0.0.12.
7	P0.0.11	If MODE is pressed directly without pressing ENTER key in the 5 th step, the keyboard will return to parameter display of P0.0.11, and data modification will not be saved, and the acceleration time stays at 010.0 without change.
8	50.00	Press MODE key to return to set frequency of monitoring

Cautions: Data cannot be modified in any of the following situations.

1. Parameters cannot be adjusted when the frequency inverter is running. (See Functional Parameters Table)

Chapter IV Keyboard Operation and Running

4.3.3 Keyboard monitoring data

CDI-SPD series photovoltaic pump drive offers 3 function code display modes: Basic mode, user mode and calibration mode.

● **Primary mode (P0.0.01=0)**

In primary mode, the function code has the prefix with ‘P’. At this time, the Function Code P5.0.17 determines what parameters of the function codes are specifically displayed. Its ones, tens, hundreds and thousands respectively correspond to each function code group. Refer to the following table for explanation of specific meaning:

Function code	Setting scope		Description
Function code parameter displays P5.0.17 is selected	Ones	0	Only display fundamental group parameter
		1	Display menus at all levels
	Tens	0	Not display P7 group
		1	Display P7 group
	Hundreds	0	Reserved
		1	Not display correction group
	Thousands	0	Display correction group
		1	Not display password group

● **User mode (P0.0.01=1)**

Only the function code parameter of user function customization is displayed, which function code parameter of inverter depends on the 7.0 group function code, and at most 30 can be customized. Under user mode, the prefix of function code is ‘U’.

Function code	Setting scope	Description
P7.0.00	U0.0.01	When the function code parameter is set, it'll be regarded as the user customization function code. At most 30 codes can be selected.
.....	U0.0.00~UX.X.XX (Not including P7 and P8 group)	
P7.0.29	U0.0.00~UX.X.XX (Not including P7 and P8 group)	

● **Check mode (P0.0.01=2)**

Only the modified parameter is displayed (when the parameter value of function mode is different from the Factory value, it'll be regarded as the modified one), under check mode, the prefix of function code is ‘C’.

Chapter V Commissioning Instructions

	<ul style="list-style-type: none"> ● Before the terminal operation of SPD series water pump driver, all power supply connected to the inverter must be cut off, and the waiting time after the power supply is cut off is not shorter than the time marked by the inverter. ● When the SPD series water pump driver is running, there is a high voltage inside, and any operation other than the keyboard setting of the inverter is prohibited ● The SPD series water pump driver defaults to power on and runs automatically. If you need to set parameters, please strictly follow the instructions in this chapter.
---	--

5.1 Check before operation

Be sure to confirm the following items before turning on the power.

- a) Check whether the SPD series water pump driver is reliably grounded;
- b) Check whether the wiring is correct and reliable;
- c) Check whether the selection of AC and DC circuit breakers is correct;
- d) Check whether the DC input voltage is within the allowable range of the inverter;
- e) Check whether the motor type, voltage and power match the inverter type, voltage and power.

5.2 Commissioning

Operation guide of asynchronous machine water pump

① Wiring:

- a. Check whether the model is matched with the solar panel;
- b. Insert “+” and “-” of solar panel to “+” or “-” of frequency converter, or terminal block R and T; avoid reverse connection to the “+” and “-” polarity of frequency converter; otherwise, the machine will be damaged.
- c. Connect motor wire and ground wire to the Terminal U, V, W and E respectively.

② Parameter setting and commissioning:

- a. Set P0.0.02 as 0 and P0.0.03 as 0; set P0.0.07, P0.0.08, P0.0.11 and P0.0.12 required;
- b. Set parameter of water pump motor according to nameplate parameter P0.0.14-P0.0.18, photovoltaic water pump P6.2.00=1 or 2;

Chapter V Commissioning Instructions

c. Press “RUN” key to start commissioning and confirm the running direction of pump motor.

③ Common faults:

a. Q: Light condition is good and pump is running, but there’s few effluent; A: Check whether the motor of water pump has reverse rotation;

b. Q: Light condition is good and the frequency converter is under 0.00Hz standby status; A: Check P6.2.01; check the protection status of frequency converter; check whether protection status parameters are set reasonably;

c. Q: Light condition is good, frequency jitter is strong when frequency converter is running; A: Adjust P6.2.10 value reasonably; it is suggested to set it near the default value, otherwise, frequency oscillation may occur.

Chapter VI Functional Parameters Table

Description for Tables of Function Parameters:

1. By function, the functional code parameters of SPD series photovoltaic water pump drive can be divided into 9 groups, each of which contain multiple sub-groups and each group includes several function codes. The function codes can be given different values.

2. The content such as PX.X.XX in the Function Table and other content of this Manual indicate the No. "XX" function code of Group "X.X"; for instance, "P0.0.01" indicates No. 01 function code of Group P0.0.

3. The column content of Function Table is described as follows:

The "Function code" of the 1st column: indicating the number of function code parameter; the "Function name" of the 2nd column: indicating the complete name of function code parameter; the "Setting scope" of the 3rd column: indicating the valid range of reference value of function code parameter; the "Factory value" of the 4th column: indicating the factory reference value of function code parameter; the "Modification limit" of the 5th column: indicating the modification attribute of function code parameter (namely whether modification is permitted or condition can be modified);

The description of function code parameter modification limit is as follows:

“☆” : The set value of this parameter can be modified when frequency converter is under shutdown or running status;

“★” : The set value of this parameter cannot be modified when frequency converter is under running status;

“●” : The value of this parameter is measured value and unalterable

“○” : This parameter can be modified only if P5.0.18=2

Note:

Explanation:

The user shall read this Manual thoroughly when the frequency inverter parameter is modified. If the user doesn't know how to use special function, contact the Technical Department of our company, and we'll provide safe and reliable technical support service. The user can't modify the data randomly; else severe fault will occur to cause severe property loss. The user will undertake the consequence without abiding by this warning!

Chapter VI Functional Parameters Table

6.1 Group P0 - Basic Function

Function code	Function name	Setting scope	Factory value	Modification on limit
Group P0.0 Basic Group				
P0.0.00	Type of Frequency drive	1: G type (constant torque load type) 2: P type (air-blower, water pump load type)	Machine type	○
P0.0.01	Display mode	0: Primary mode (prefix is "P") 1: User mode (prefix is "U") 2: Check mode (prefix is "C")	0	☆
P0.0.02	Control mode	0: V/F control 1: Reserved 2: Reserved	0	★
P0.0.03	Option of operation control mode	0: Keypad control 1: Terminal control 2: Communication control	0	☆
P0.0.04	Option of A Frequency Source	0: Keypad Reference (No Power-off Memory) 1: Keypad Reference (Power-off Memory) 2: Keypad Potentiometer Reference 3: Analog input VF1 is given 4: Analog input VF2 is given 5: Reserved 6: Multiplex Directive Reference 7: Simple PLC Reference 8: PID Control Reference 9: Communication Reference 10~13: Reserved	00	★
P0.0.05	Keypad Frequency Reference	000.00~Highest Frequency	050.00	☆
P0.0.06	Running Direction	0: Default Direction 1: Negation of Direction 2: Determined by multi-functional input terminal	0	☆
P0.0.07	Max. frequency	050.00Hz~320.0Hz	050.00	★
P0.0.08	Upper limit frequency	Lower limit frequency ~ Max. frequency	050.00	★
P0.0.09	Lower limit frequency	000.00~Upper limit frequency	000.00	☆
P0.0.10	Lower frequency operation mode	0: Running at lower limit frequency 1: Stop 2: Zero-speed Running	0	☆
P0.0.11	Acceleration time	0000.0~6500.0s	Machine type	☆
P0.0.12	Deceleration time	0000.0~6500.0s	Machine type	☆
P0.0.13	Type of Motor	0: Common motor 1: Variable-frequency motor 2: Reserved	0	★
P0.0.14	Motor rated power	0000.1kw~1000.0kw	Machine type	★
P0.0.15	Motor rated frequency	000.01Hz~Highest Frequency	050.00	★

Chapter VI Functional Parameters Table

Function code	Function name	Setting scope	Factory value	Modification limit
P0.0.16	Motor rated voltage	0001V~2000V	Machine type	★
P0.0.17	Motor rated current	000.01A~655.35A	Machine type	★
P0.0.18	Motor Rated Speed	00001rpm~65535 rpm	Machine type	★
P0.0.19	Stator resistance of asynchronous motor	00.001 Ω ~ 65.535 Ω	Machine type	★
P0.0.20	Rotor resistance of asynchronous motor	00.001 Ω ~ 65.535 Ω	Machine type	★
P0.0.21	Leakage inductance of asynchronous motor	000.01mH~655.35mH	Machine type	★
P0.0.22	Mutual inductance of asynchronous motor	0000.1mH~6553.5mH	Machine type	★
P0.0.23	Non-load current of asynchronous motor	000.01A~Motor rated current	Machine type	★
P0.0.24	Parameter identification control	00: No action 01: Static identification 02: Complete identification 11~12: Reserved	00	★
P0.1 Group: Expansion Group				
P0.1.00~P0.1.02	Reserved	--	--	--
P0.1.03	Upper Limit Frequency Source	0: Digital Reference (P0.0.08) 1: Analog input VF1 is given 2: Analog input VF2 is given 3: Multiplex Directive Reference 4: Reserved 5: Communication Reference 6~9: Reserved	0	★
P0.1.04	Upper Limit Frequency Offset	000.00~Highest Frequency	000.00	☆
P0.1.05	Keyboard Reference frequency Shut-down Memory Selection	0: No Memory 1: Memory	0	☆
P0.1.06	Keyboard Reference frequency Action Benchmark at running	0: Running Frequency 1: Reference frequency	0	★
P0.1.07	Benchmark frequency of accelerating and Deceleration time	0: Highest Frequency 1: Reference frequency 2: 100Hz	0	★
P0.1.08	Jogging running frequency	000.00~Highest Frequency	002.00	☆
P0.1.09	Jogging Acceleration time	0000.0s~6500.0s	0020.0	☆
P0.1.10	Jogging Deceleration time	0000.0s~6500.0s	0020.0	☆

Chapter VI Functional Parameters Table

Function code	Function name	Setting scope	Factory value	Modification limit
P0.1.11	Acceleration time 2	0000.0s~6500.0s	Machine type	☆
P0.1.12	Deceleration time 2	0000.0s~6500.0s	Machine type	☆
P0.1.13	Acceleration time 3	0000.0s~6500.0s	Machine type	☆
P0.1.14	Deceleration time 3	0000.0s~6500.0s	Machine type	☆
P0.1.15	Acceleration time 4	0000.0s~6500.0s	Machine type	☆
P0.1.16	Deceleration time 4	0000.0s~6500.0s	Machine type	☆
P0.1.17	Frequency Switch Point between Acceleration time 1 and Acceleration time 2	000.00Hz~Highest Frequency	000.00	☆
P0.1.18	Frequency Switch Point between Deceleration time 1 and Deceleration time 2	000.00Hz~Highest Frequency	000.00	☆
P0.1.19	Acceleration and Deceleration Mode	0: Straight Line 1: Curve S 1 2: Curve S 2	0	★
P0.1.20	Percentage of Starting Phase of Curve S	000.0%~100.0%	030.0	★
P0.1.21	Percentage of Ending Phase of Curve S	000.0%~100.0%	030.0	★
P0.1.22	Hopping Frequency 1	000.00Hz~Highest Frequency	000.00	☆
P0.1.23	Hopping Frequency 2	000.00Hz~Highest Frequency	000.00	☆
P0.1.24	Hopping Frequency scope	000.00Hz~Highest Frequency	000.00	☆
P0.1.25	Jogging Priority	0: Invalid 1: Valid	0	☆
P0.1.35	Switching frequency point of deceleration time 2 and deceleration time 3	000.00Hz ~ max. frequency	0.00	☆
P0.1.36	Reserved	--	--	--

6.2 Group P1 - Motor Control Parameter

Function code	Function name	Setting scope	Factory value	Modification limit
Sort P1.0: Basic Group				
P1.0.00	V/F Curve Mode	0: Straight Line 1: Multi-point Broken Line 2: Square V/F Curve 1 3: Square V/F Curve 2	0	★

Chapter VI Functional Parameters Table

Function code	Function name	Setting scope	Factory value	Modification limit
		4: Square V/F Curve 3		
P1.0.01	Torque Boost	00.0% (Automatic Torque Boost) 00.1%~30.0%	Machine type	☆
P1.0.02	Cutoff Frequency of Torque Boost	000.00Hz~Highest Frequency	050.00	
P1.0.03	V/F Slip Compensation Gain	000.0%~200.0%	000.0	☆
P1.0.04	Velocity Loop Proportional Gain 1	001~100	030	☆
P1.0.05	Velocity Circulation Integral Time 1	00.01~10.00	00.50	☆
P1.0.06	Switching Frequency 1	000.00Hz~P1.0.09	005.00	☆
P1.0.07	Velocity Loop Proportional Gain 2	001~100	020	☆
P1.0.08	Velocity Circulation Integral Time 2	00.01~10.00	01.00	☆
P1.0.09	Switching Frequency 2	P1.0.06~Highest Frequency	010.00	☆
P1.0.10	Start Mode	0: Direct Start 1: Speed Tracking Mode 2: Brake and Restart	0	☆
P1.0.11	Speed Tracking Mode	0: Start from Shutdown Frequency 1: Start from Zero Speed 2: Start from Highest Frequency	0	★
P1.0.12	Start Frequency	00.00Hz~10.00Hz	00.00	☆
P1.0.13	Hold Time of Start Frequency	000.0s~100.0s	000.0	★
P1.0.14	Starting DC Brake Current	000%~100%	000	★
P1.0.15	Starting DC Brake Time	000.0s~100.0s	000.0	★
P1.0.16	Stop mode	0: Stop by Deceleration 1: Free Stop	1	☆
P1.0.17	Stop DC Braking Initial Frequency	000.00Hz~Highest Frequency	000.00	☆
P1.0.18	Stop DC Braking Waiting Time	000.0s~100.0s	000.0	☆
P1.0.19	Stop DC Braking Current	000%~100%	000	☆
P1.0.20	Stop DC Braking Time	000.0s~100.0s	000.0	☆
P1.0.21	Braking Use Rate	000%~100%	100	☆
P1.0.22	Carrier Frequency	00.5kHz~16.0 kHz	Machine type	☆
P1.0.23	Fan Control	0: Rotate at running 1: Continuous Running 2: Control based on Temperature	0	★
P1.0.24	Motor Overload Protection	0: Prohibition 1: Curve 1 2: Curve 2 3: Curve 3	1	☆
P1.0.25	Motor Overload	00.20~10.00	01.00	☆

Chapter VI Functional Parameters Table

Function code	Function name	Setting scope	Factory value	Modification limit
	Protection Level			
P1.0.26	Motor Overload Alarm System	050%~100%	080	☆
Group P1.1: Extension Group				
P1.1.00	V/F Point 1 Frequency	000.00Hz~P1.1.02	000.00	★
P1.1.01	V/F Point 1 Voltage	000.0%~100.0%	000.0	★
P1.1.02	V/F Point 2 Frequency	P1.1.00~P1.1.04	000.00	★
P1.1.03	V/F Point 2 Voltage	000.0%~100.0%	000.0	★
P1.1.04	V/F Point 3 Frequency	P1.1.02~Motor rated frequency	000.00	★
P1.1.05	V/F Point 3 Voltage	000.0%~100.0%	000.0	★
P1.1.06	V/F Overexcited Gain	000~200	120	☆
P1.1.07	Vector Control Torque Upper Frequency	0: Digital Reference (P1.1.08) 1: Analog input VF1 is given 2: Analog input VF2 is given 3: Multiplex Directive Terminal Reference 4: Reserved 5: Communication Reference 6: MIN (VF1, VF2) 7: MAX (VF1, VF2) 8~13: Reserved	00	☆
P1.1.08	Torque Upper Limit Reference	000.0%~200.0%	150.0	☆
P1.1.09	Inversion Control Enable	0: Allow 1: Prohibit	0	☆
P1.1.10	Forward and Reverse Dead Time	0000.0s~3000.0s	0000.0	☆
P1.1.11	Power-on Running Selection	0: Running 1: Not Running	0	☆
P1.1.12~P1.1.19	Reserved	--	--	--

6.3 Group P2 - Input/Output Terminal Function

Function code	Function name	Setting scope	Factory value	Modification limit
Group P2.0: Basic Group				
P2.0.00	DI1 Terminal Function	0: No Function 1: Forward (FWD)	01	★
P2.0.01	DI2 Terminal Function	2: Reverse (REV) 3: Three-wire Running Control	02	★
P2.0.02	DI3 Terminal Function	4: Forward Jogging 5: Reverse Jogging	61	★
P2.0.03	DI4 Terminal Function	6: Terminal UP 7: Terminal DOWN	59	★
P2.0.04	DI5 Terminal Function	8: Free Stop 9: Multiplex Directive Terminal 1	11	★
P2.0.05	DI6 Terminal	10: Multiplex Directive Terminal 2 11: Multiplex Directive Terminal 3	0	★

Chapter VI Functional Parameters Table

Function code	Function name	Setting scope	Factory value	Modification limit
	Function			
Group P2.0: Basic Group				
P2.0.06~ P2.0.09	Reserved	12: Multiplex Directive Terminal 4 13: Fault Reset (RESET) 14: Running Pause 15: External Fault Input 16: Acceleration & Deceleration Time Selection Terminal 1 17: Acceleration & Deceleration Time Selection Terminal 2 18~20: Reserved 21: Running Command Selection Terminal 1 22: Running Command Selection Terminal 2 23: UP/DOWN Reference Reset 24: Prohibition of Acceleration & Deceleration 25: PID Pause 26: PLC State Reset 27~33: Reserved 34: Immediate DC Brake 35: External Fault Normally-closed Input 36: Frequency Modification Enable 37: PID Action Direction Negation 38: External Stop Terminal 1 39: External Stop Terminal 2 40: PID Integral Stop 41: PID Parameter Switch 42: Reserved 43: Emergency Stop 44: Deceleration DC Brake 45: User-Defined Fault 1 46: User-Defined Fault 2 47: Running Time Reset 48~58: Reserved 59: Switch to general mode by force (take effects at shutdown status) 60: AC/DC mode switching 61: Full water signal		
P2.0.10	DI Filtering time	0.000s~1.000s	0.010	☆
P2.0.11	External Terminal Running Control Mode	0: Two-line Type 1 1: Two-line Type 2 2: Three-line Type 1 3: Three-line Type 2	0	★
P2.0.12	UP/DOWN Terminal Change Rate	00.001Hz/s~65.535Hz/s	01.000	☆
P2.0.13	Minimum Input of Curve 1	00.00V~P2.0.15	00.00	☆

Chapter VI Functional Parameters Table

Function code	Function name	Setting scope	Factory value	Modification limit
P2.0.14	Corresponding reference for Minimum Input of Curve 1	-100.0%~100.0%	000.0	☆
P2.0.15	Maximum Input of Curve 1	P2.0.13~10.00V	10.00	☆
P2.0.16	Corresponding reference for Maximum Input of Curve 1	-100.0%~100.0%	100.0	☆
P2.0.17	VF1 Filtering time	00.00s~10.00s	00.10	☆
P2.0.18	Minimum Input of Curve 2	00.00V~P2.0.20	00.00	☆
P2.0.19	Corresponding reference for Minimum Input of Curve 2	-100.0%~100.0%	000.0	☆
P2.0.20	Maximum Input of Curve 2	P2.0.18~10.00V	10.00	☆
P2.0.21	Corresponding reference for Maximum Input of Curve 2	-100.0%~100.0%	100.0	☆
P2.0.22	VF2 Filtering time	0.00s~10.00s	00.10	☆
P2.0.23 ~ P2.0.27	Reserved	--	--	--
P2.0.28	Reserved	0: No Function	--	--
P2.0.29	T1 Relay Function Selection	1: Frequency drive under Running 2: Fault Stop Output 3: Frequency Level Testing FDT1 Output 4: Frequency Arrival 5: Zero-speed Running (no output when shut down) 6: Motor Overload Pre-alarm 7: Frequency drive Overload Pre-alarm 8~10: Reserved 11: PLC circulation cycle completed 12: Accumulative Running Time Arrival 13: Frequency Limit 14: Reserved 15: Ready for Running 16: VF1>VF2 17: Upper Frequency Arrival 18: Lower Frequency Arrival (no output when shut down) 19: Under-voltage state output 20: Communication Reference 21: VF1 Output less than Lower Limit	60	
P2.0.30	Reserved		--	--

Chapter VI Functional Parameters Table

Function code	Function name	Setting scope	Factory value	Modification limit
P2.0.30	Reserved	22: VF1 Output more Upper Limit 23: Zero-speed Running 2 (also output when shut down) 24: Accumulative Power-on Time Arrival 25: Frequency Level Testing FDT2 Output 26: Frequency 1 Arrival Output 27: Frequency 2 Arrival Output 28: Current 1 Arrival Output 29: Current 2 Arrival Output 30: Timing Arrival Output 31: VF1 Input Over-limit 32: In Off-load 33: In Reverse Running 34: Zero-current State 35: Module Temperature Arrival 36: Output Current Over-limit 37: Lower Frequency Arrival (also output when shut down) 38: Alarm Output 39: PLC Phase Completed 40: Current Running Time Arrival 41: Fault Output (Not Output for Under-voltage) 42: Timer 1 Timing Arrival 43: Timer 2 Timing Arrival 44: Timer 1 Timing Arrival but Timer 2 Timing Not Arrival 45: User Function 1 46: User Function 2 47: User Function 3 48: User Function 4 49: User Function 5 50~59: Reserved 60: Switch to PV mode 61: Mppt max. voltage under amplitude limiting		
P2.0.33	Analog Output FM1 Reference	0: Running Frequency 1: Reference frequency 2: Output Current 3: Output Torque (Absolute Value of Torque) 4: Output Power 5: Output Voltage 6: Reserved 7: VF1 Voltage 8: VF1 Voltage 9: Keyboard Potentiometer Voltage	00	☆
P2.0.34	Reserved	10~11: Reserved 12: Communication Reference 13: Motor Speed	--	--

Chapter VI Functional Parameters Table

Function code	Function name	Setting scope	Factory value	Modification limit
		14: Output Current 15: Bus line voltage 16: Output Torque 17~20: Reserved		
P2.0.35	Reserved		---	---
P2.0.36	Analog FM1 Output Offset	-100.0%~100.0%	000.0	☆
P2.0.37	Analog FM1 Output Gains	-10.00~10.00	01.00	☆
P2.0.38	Reserved	---	---	---
P2.0.39	Reserved	---	---	---
Group P2.1: Expansion Group				
P2.1.00	Valid Model Selection 1 of Terminal DI	0: Active High Level 1: Active Low Level Ones: DI1 Tens: DI2 Hundreds: DI3 Thousands: DI4 Ten Thousands: DI5	00000	★
P2.1.01	Valid Model Selection 2 of Terminal DI	0: Active High Level 1: Active Low Level Ones: DI6 Tens ~ Ten Thousands: Reserved	00000	★
P2.1.02	Analog Input Curve Selection	Ones: Curve selected for VF1 Tens: Curve selected for VF2 1: Curve 1 2: Curve 2 3: Curve 3 4: Curve 4 Hundreds: VF1 Input resolution Thousands: VF2 Input resolution Ten Thousands: Keyboard Potentiometer input resolution 0:00.01Hz 1:00.02Hz 2:00.05Hz 3:00.10Hz 4:00.20Hz 5:00.50Hz 6:01.00Hz(Keyboard Potentiometer is invalid)	00021	☆
P2.1.03	Selection for Curve less than Min. Reference	0: Corresponding Min. Input Reference 1: 0.0% Ones: VF1 Tens: VF2	H.00	☆
P2.1.04	Min. Input of Curve 3	00.00V~P2.1.06	00.00	☆
P2.1.05	Corresponding reference for Min. Input of Curve 3	-100.0%~100.0%	000.0	☆
P2.1.06	Curve 3 Inflection Point 1 Input	P2.1.04~P2.1.08	03.00	☆

Chapter VI Functional Parameters Table

Function code	Function name	Setting scope	Factory value	Modification limit
P2.1.07	Corresponding reference for Curve 3 Inflection Point 1 Input	-100.0%~100.0%	030.0	☆
P2.1.08	Curve 3 Inflection Point 2 Input	P2.1.06~P2.1.10	06.00	☆
P2.1.09	Corresponding reference for Curve 3 Inflection Point 2 Input	-100.0%~100.0%	060.0	☆
P2.1.10	Max. input of Curve 3	P2.1.08~10.00V	10.00	☆
P2.1.11	Corresponding reference for Max. input of Curve 3	-100.0%~100.0%	100.0	☆
P2.1.12	Min. Input of Curve 4	00.00V~P2.1.14	00.00	☆
P2.1.13	Corresponding reference for Min. Input of Curve 4	-100.0%~100.0%	-100.0	☆
P2.1.14	Curve 4 Inflection Point 1 Input	P2.1.12~P2.1.16	03.00	☆
P2.1.15	Corresponding reference for Curve 4 Inflection Point 1 Input	-100.0%~100.0%	-030.0	☆
P2.1.16	Curve 4 Inflection Point 2 Input	P2.1.14~P2.1.18	06.00	☆
P2.1.17	Corresponding reference for Curve 4 Inflection Point 2 Input	-100.0%~100.0%	030.0	☆
P2.1.18	Max. input of Curve 4	P2.1.16~10.00V	10.00	☆
P2.1.19	Corresponding reference for Max. input of Curve 4	-100.0%~100.0%	100.0	☆
P2.1.20 P2.1.21	Reserved	--	--	--
P2.1.22	Valid State of Multi-functional	0:Positive logic 1:Negative logic	00000	☆

Chapter VI Functional Parameters Table

Function code	Function name	Setting scope	Factory value	Modification limit
	Output Terminal	Ones: Reserved Tens: T1 Hundreds ~ Ten Thousands: Reserved		
P2.1.23	VF1 Terminal Function as Digital Input	00: Use as Normal Analog 01 ~ 59: Digital Input Terminal Function	00	★
P2.1.24	VF2 Terminal Function as Digital Input	00: Use as Normal Analog 01~59: Digital Input Terminal Function	00	★
P2.1.25	Valid State Option of VF	0: Active High Level 1: Active Low Level Ones: VF1 Tens: VF2	00	★
P2.1.26	DI1 Delay	0.0s~3600.0s	0000.0	☆
P2.1.27	DI2 Delay	0.0s~3600.0s	0000.0	☆
P2.1.28	DI3 Delay	0.0s~3600.0s	0000.0	☆
P2.1.29	Reserved	--	--	--
P2.1.30	T1 Delay	0.0s~3600.0s	0000.0	☆
P2.1.31	Reserved	--	--	--
P2.1 Group: Extension Group (asynchronous motor 1.35 version has this function)				
P2.1.32	DI1 ineffective delay (this function is unavailable when unable to be set)	0.0s~3600.0s	0000.0	△/☆
P2.1.33	DI2 ineffective delay (this function is unavailable when unable to be set)	0.0s~3600.0s	0000.0	☆
P2.1.34	DI3 ineffective delay (this function is unavailable when unable to be set)	0.0s~3600.0s	0000.0	☆
Group P2.2 Auxiliary Group				
P2.2.00	Accumulative Power-on Reaches Reference Time	00000h~65000h	00000	☆
P2.2.01	Accumulative Running Reaches Reference Time	00000h~65000h	00000	☆

Chapter VI Functional Parameters Table

Function code	Function name	Setting scope	Factory value	Modification limit
P2.2.02	The reference frequency reaches test width	000.0%~100.0%	000.0	☆
P2.2.03	Frequency Test FDT1	000.00Hz~Highest Frequency	050.00	☆
P2.2.04	FDT1 Lagged Value	000.0%~100.0%	005.0	☆
P2.2.05	Frequency Test FDT2	000.00Hz~Highest Frequency	050.00	☆
P2.2.06	FDT2 Lagged Value	000.0%~100.0%	005.0	☆
P2.2.07	Any reached frequency tested value 1	000.00Hz~Highest Frequency	050.00	☆
P2.2.08	Any reached frequency 1 test width	000.0%~100.0%	000.0	☆
P2.2.09	Any reached frequency tested value 2	000.00Hz~Highest Frequency	050.00	☆
P2.2.10	Any reached frequency 2 test width	000.0%~100.0%	000.0	☆
P2.2.11	Zero Current Test Level	000.0%~300.0% (100.0% correspond to rated current of motor)	005.0	☆
P2.2.12	Delay Time for Zero Current Test	000.01s~600.00s	000.10	☆
P2.2.13	Output Current Overlimit Value	00.0: No Test 000.1%~300.0%	200.0	☆
P2.2.14	Delay Time for Current Overlimit Test	000.00s~600.00s	000.00	☆
P2.2.15	Current Level Test 1	000.0%~300.0%	100.0	☆
P2.2.16	Test Width of Current Level 1	000.0%~300.0%	000.0	☆
P2.2.17	Current Level Test 2	000.0%~300.0%	100.0	☆
P2.2.18	Test Width of Current Level 2	000.0%~300.0%	000.0	☆
P2.2.19	VF1 Input Lower	00.00V~P2.2.20	03.10	☆

Chapter VI Functional Parameters Table

Function code	Function name	Setting scope	Factory value	Modification limit
	Limit			
P2.2.20	VF1 Input Upper Limit	P2.2.19~11.00V	06.80	☆
P2.2.21	Model Temperature Reaches Reference	000℃~100℃	075	☆
P2.2.22	Current Running Reaches Reference Time	0000.0 min~6500.0 min	0000.0	★

6.4 Group P3 - Programmable Function

Function code	Function name	Setting scope	Factory value	Modification limit
Group P3.0: Basic Group				
P3.0.00	Simple PLC Running Mode	0: End of Single Running and Stop 1: End of Single Running and Save Final Value 2: Continuous Running 3: Cycle N Times	0	☆
P3.0.01	Cycle number(s), N	00000~65000	00000	☆
P3.0.02	Option of PLC Power-off Memory	Ones: Option of Power-off Memory 0: No Power-off Memory 1: Power-off Memory Tens: Stop Memory Selection 0: No Stop Memory 1: Stop Memory	00	☆
P3.0.03	Phase Directive 0	-100.0%~100.0%	000.0	☆
P3.0.04	Phase 0 Running Time	0000.0s~6500.0s	0000.0	☆
P3.0.05	Phase Directive 1	-100.0%~100.0%	000.0	☆
P3.0.06	Phase 1 Running Time	0000.0s~6500.0s	0000.0	☆
P3.0.07	Phase Directive 2	-100.0%~100.0%	000.0	☆
P3.0.08	Phase 2 Running Time	0000.0s~6500.0s	0000.0	☆
P3.0.09	Phase Directive 3	-100.0%~100.0%	000.0	☆
P3.0.10	Phase 3 Running Time	0000.0s~6500.0s	0000.0	☆
P3.0.11	Phase Directive 4	-100.0%~100.0%	000.0	☆
P3.0.12	Phase 4 Running Time	0000.0s~6500.0s	0000.0	☆
P3.0.13	Phase Directive 5	-100.0%~100.0%	000.0	☆
P3.0.14	Phase 5 Running Time	0000.0s~6500.0s	0000.0	☆
P3.0.15	Phase Directive 6	-100.0%~100.0%	000.0	☆
P3.0.16	Phase 6 Running Time	0000.0s~6500.0s	0000.0	☆
P3.0.17	Phase Directive 7	-100.0%~100.0%	000.0	☆
P3.0.18	Phase 7 Running Time	0000.0s~6500.0s	0000.0	☆
P3.0.19	Phase Directive 8	-100.0%~100.0%	000.0	☆

Chapter VI Functional Parameters Table

Function code	Function name	Setting scope	Factory value	Modification limit
P3.0.20	Phase 8 Running Time	0000.0s~6500.0s	0000.0	☆
P3.0.21	Phase Directive 9	-100.0%~100.0%	000.0	☆
P3.0.22	Phase 9 Running Time	0000.0s~6500.0s	0000.0	☆
P3.0.23	Phase Directive 10	-100.0%~100.0%	000.0	☆
P3.0.24	Phase 10 Running Time	0000.0s~6500.0s	0000.0	☆
P3.0.25	Phase Directive 11	-100.0%~100.0%	000.0	☆
P3.0.26	Phase 11 Running Time	0000.0s~6500.0s	0000.0	☆
P3.0.27	Phase Directive 12	-100.0%~100.0%	000.0	☆
P3.0.28	Phase 12 Running Time	0000.0s~6500.0s	0000.0	☆
P3.0.29	Phase Directive 13	-100.0%~100.0%	000.0	☆
P3.0.30	Phase 13 Running Time	0000.0s~6500.0s	0000.0	☆
P3.0.31	Phase Directive 14	-100.0%~100.0%	000.0	☆
P3.0.32	Phase 14 Running Time	0000.0s~6500.0s	0000.0	☆
P3.0.33	Phase Directive 15	-100.0%~100.0%	000.0	☆
P3.0.34	Phase 16 Running Time	0000.0s~6500.0s	0000.0	☆
P3.0.35	Phase 0 attribution	Ones: Acceleration & Deceleration Time Selection (Invalid Multiplex Directive) 0: Acceleration & Deceleration Time 1 1: Acceleration & Deceleration Time 2 2: Acceleration & Deceleration Time 3 3: Acceleration & Deceleration Time 4 Tens: Frequency Source Selection (Valid Multiplex Directive) 0: Current Phase Directive 1: Keyboard Potentiometer 2: Keyboard Frequency Reference 3: VF1 Input 4: VF2 Input 5: Reserved 6: PID Reference 7~10: Reserved Hundreds unit: running direction 0: Default direction 1: Reversed direction	H.000	☆
P3.0.36	Phase 1 attribution		H.000	☆
P3.0.37	Phase 2 attribution		H.000	☆
P3.0.38	Phase 3 attribution		H.000	☆
P3.0.39	Phase 4 attribution		H.000	☆
P3.0.40	Phase 5 attribution		H.000	☆
P3.0.41	Phase 6 attribution		H.000	☆
P3.0.42	Phase 7 attribution		H.000	☆
P3.0.43	Phase 8 attribution		H.000	☆
P3.0.44	Phase 9 attribution		H.000	☆
P3.0.45	Phase 10 attribution		H.000	☆
P3.0.46	Phase 11 attribution		H.000	☆
P3.0.47	Phase 12 attribution		H.000	☆
P3.0.48	Phase 13 attribution		H.000	☆
P3.0.49	Phase 14 attribution		H.000	☆
P3.0.50	Phase 15 attribution	H.000	☆	
P3.0.51	Simple PLC Running Time Unit	0: Second 1: Hour 2: Minute	0	☆
Group P3.1: Expansion Group				
P3.1.00	Timing Function Selection	0: Ineffective 1: Effective (min) 2: Effective (h) (this function is unavailable when unable to be set as 2)	0	★
P3.1.01	Fixed Running Time Selection	0: Digital Reference (P3.1.02) 1: Analog input VF1 is given 2: Analog input VF2 is given (Analog input range corresponds to P3.1.02)	0	★
P3.1.02	Fixed Running Time	0000.0min/h~6500.0min/h (unit depends on P3.1.00)	0000.0	★

Chapter VI Functional Parameters Table

Function code	Function name	Setting scope	Factory value	Modification limit
P3. 1. 03 ~ P3. 1. 15	Reserved	--	--	--

6. 5 Group P4 - PID Control and Communication Control

Function code	Function name	Setting scope	Factory value	Modification limit
Group P4.0: PID Control Group				
P4.0.00	PID Reference Source	0: Digital Reference (P4.0.01) 1: Keyboard Potentiometer Reference 2: Analog input VF1 is given 3: Analog input VF2 is given 4: PULS Impulse Reference (DI6) 5: Communication Reference 6: Multiplex Directive Terminal Reference 7: Simple PLC Reference 8~11: Reserved	00	☆
P4.0.01	PID Value Reference	000.0%~100.0%	050.0	☆
P4.0.02	PID Feedback Source	0: Analog input VF1 is given 1: Analog input VF2 is given 2: VF1-VF2 3: VF1+VF2 4: Reserved 5: Communication Reference 6: MAX[VF1, VF2] 7: MIN[VF1, VF2] 8: Switch of Multiplex Directive Terminal on the above conditions 9~12: Reserved	00	☆
P4.0.03	PID Action Direction	0: Direct Action 1: Reverse Action	0	☆
P4.0.04	PID Reference Feedback Range	00000~65535	01000	☆
P4.0.05	Proportional Gains KP1	000.0~100.0	020.0	☆
P4.0.06	Integral Time TI1	00.01s~10.00s	02.00	☆
P4.0.07	Derivative Time TD1	00.000s~10.000s	00.000	☆
P4.0.08	PID Deviation Limit	000.0%~100.0%	000.0	☆
P4.0.09	PID Feedback Filtering time	00.00s~60.00s	00.00	☆
P4.0.10	Proportional Gains KP2	000.0~100.0	020.00	☆
P4.0.11	Integral Time TI2	00.01s~10.00s	02.00	☆
P4.0.12	Derivative Time TD2	00.000s~10.000s	00.000	☆
P4.0.13	PID Switch Conditions	0: No Switch 1: Switch through Terminals 2: Switch through Deviation	0	☆
P4.0.14	PID Switch Deviation 1	000.0%~P4.0.15	020.0	☆
P4.0.15	PID Switch Deviation 2	P4.0.14~100.0%	080.0	☆
P4.0.16	PID Initial Value	000.0%~100.0%	000.0	☆

Chapter VI Functional Parameters Table

Function code	Function name	Setting scope	Factory value	Modification limit
P4.0.17	PID Initial Value Hold Time	000.00~650.00s	000.00	☆
P4.0.18	PID Feedback Loss Detection	000.0%: No Judgment on Feedback Loss 000.1%~100.0%	000.0	☆
P4.0.19	PID Feedback Loss Detection Time	00.0s~20.0s	00.0	☆
P4.0.20	PID Stop Operation	0: No Operation 1: Operation	0	☆
P4.0.21	Sleep threshold value	0.0%~100.0%	100.0%	☆
P4.0.22	Sleep time	0.0s~6000.0s	30.0s	☆
P4.0.23	Awakening threshold value	0.0%~100.0%	0.0%	☆
P4.0.24	Awakening time	0.0s~6000.0s	30.0s	☆
Group P4.1: Communication Group				
P4.1.00	Baud Rate	Ones: MODBUS baud rate 0:1200 1:2400 2:4800 3:9600 4:19200 5:38400 6:57600 Tens: Invalid	03	☆
P4.1.01	Data Format	0: No check (8-N-2) 1:Even parity check (8-E-1) 2:Odd parity check(8-0-1) 3:No check (8-N-1)	0	☆
P4.1.02	Local Machine Address	000: Broadcast Address 001~249	001	☆
P4.1.03	Response Delay	00~20ms	02	☆
P4.1.04	Communication Timeout	00.0 (Invalid) 00.1s~60.0s	00.0	☆
P4.1.05	Data Transmission Format	Ones: MODBUS data format 0: ASCII mode (Reserved) 1: RTU mode Tens: Invalid	01	☆
P4.1.06	MODBUS communication data reply or not	0: Reply 1: No reply	0	☆
P4.1.07	Troubleshooting communication error of	0: Bypassed 1: Shutdown 2: Communication fault	0	☆

Chapter VI Functional Parameters Table

6.6 Group P5 - Keypad Display

Function code	Function name	Setting scope	Factory value	Modification limit
Group P5.0: Basic Group				
P5.0.00	Keypad JOG Key Function Reference	0: Invalid 1: Forward Jogging 2: Reverse Jogging 3: Forward and Reverse Switch	1	★
P5.0.01	Keypad STOP Key Stop Function	0: Only valid in Keypad Operation Mode 1: Valid for any Mode	1	☆
P5.0.02	LED Running Display Parameter 1	H.0001~H.FFFF Bit00: Running Frequency (Hz) Bit01: Reference frequency (Hz) Bit02: Output Current (A) Bit03: Output Voltage (V) Bit04: Bus Voltage (V) Bit05: Output Torque (%) Bit06: Output Power (kW) Bit07: Input Terminal State Bit08: Output Terminal State Bit09: VF1 Voltage (V) Bit10: VF2 Voltage (V) Bit11: Customized Display Value Bit12: Reserved Bit13: Reserved Bit14: PID Reference Bit15: PID Feedback	H.081F	☆
P5.0.03	LED Running Display Parameter 2	H.0000~H.FFFF Bit00: Reserved Bit01: Feedback Speed (Hz) Bit02: PLC Phase Bit03: VF1 Voltage before Correction (V) Bit04: VF2 Voltage before Correction (V) Bit05: Reserved Bit06: Current Power-on Time (min) Bit07: Current Running Time (min) Bit08: Residual Running Time (min) Bit09: Frequency of Frequency Source A(Hz) Bit10: Reserved Bit11: Communication Set value (Hz) Bit12: Reserved Bit13: Reserved Bit14: Reserved Bit15: User Standby Monitoring Value 1	H.081F	☆
P5.0.04	Automatic Time Switch of LED Running Display Parameter	000.0: No Switch 000.1s~100.0s	000.0	☆

Chapter VI Functional Parameters Table

Function code	Function name	Setting scope	Factory value	Modification limit
P5.0.05	LED Stop Display Parameter	H.0001~H.FFFF Bit00: Reference frequency (Hz) Bit01: Bus Voltage (V) Bit02: Input Terminal State Bit03: Output Terminal State Bit04: VF1 Voltage (V) Bit05: VF2 Voltage (V) Bit06: Actual Count Value Bit07: Actual Length Value Bit08: PLC Phase Bit09: Customized Display Value Bit10: PID Reference Bit11: PID Feedback Bit12: PULSE Impulse Frequency (Hz) Bit13: User Standby Monitoring Value 1 Bit14: Reserved Bit15: Reserved	H.0033	☆
P5.0.06 ~ P5.0.14	Reserved	--	--	--
P5.0.15	Customized Display of Coefficient	0.0001~6.5000	1.0000	☆
P5.0.16	User-defined display control word	Ones: user-defined decimal place displaying 0: zero decimal place 1: one decimal place 2: two decimal places 3: three decimal places Tens: source of user-defined display value 0: determined by hundreds place of user-defined display control word. 1: determined by set value of P5.0.15, and 0.0000~0.0099 corresponds to P9.0.00~P9.0.99 of P9 Group. Hundreds: selection of user-defined displaying coefficient 0: user-defined displaying coefficient is P5.0.15. 1: user-defined displaying coefficient is calculation result 1 2: user-defined displaying coefficient is calculation result 2 3: user-defined displaying coefficient is calculation result 3 4: user-defined displaying coefficient is calculation result 4	001	☆

Chapter VI Functional Parameters Table

Function code	Function name	Setting scope	Factory value	Modification limit
P5. 0. 17	Selection Display of Function Parameter Group	Ones: 0: Only display basic group 1: Display the menus at all levels Tens 0: Don't display Group P7 1: Display Group P7 2: Reserved Hundreds: 0: Don't display correction parameter group 1: Display correction parameter group Thousands: 0: Don't display code group 1: Display code group Ten Thousands: Reserved	11111	☆
P5. 0. 18	Function Password Protection	0: Modifiable 1: Non-modifiable 2: Allowable Modification to GP Type	0	☆
P5. 0. 19	Parameter Initialization	00: No Operation 01: Clearance of Record Information 09: Reset to Factory Parameter, excluding motor parameter, correction group, password group 19: Reset to Factory Parameter, excluding motor parameter, password group 30: Users Current Parameter Backup 60: Reset to User Backup Parameters 100~999: Reset to User Factory Parameters	000	★
P5. 0. 20	User Password	00000~65535	00000	☆
Group P5.1: Expansion Group				
P5. 1. 00	Accumulative Running Time	00000h~65000h		●
P5. 1. 01	Accumulative Power On Time	00000h~65000h		●
P5. 1. 02	Accumulative Power Consumption	00000kwh~65000kwh		●
P5. 1. 03	Module Temperature	000℃~100℃		●
P5. 1. 04	Hardware Version No.	180. 00		●
P5. 1. 05	Software Version No.	001. 00		●
P5. 1. 06	Program Non-standard Label	0000~9999		●

Chapter VI Functional Parameters Table

6.7 Group P6 - Fault Display and Protection

Function code	Function name	Setting scope	Factory value	Modification limit
Group P6.0: Fault Display Group				
P6. 0. 00	Fault Record 1 (Last Time)	0: No Fault		●
P6. 0. 01	Fault Record 2	1: Constant Over-current		●
P6. 0. 02	Fault Record 3	2: Accelerated Over-current 3: Decelerated Overcurrent 4: Constant Overvoltage 5: Accelerated Overvoltage 6: Decelerated Overvoltage 7: Module Fault 8: Under-voltage 9: Frequency drive Overload 10: Motor Overload 11: Input Default Phase 12: Output Default Phase 13: External Fault 14: Communication Abnormity 15: Frequency drive Overheat 16: Frequency drive Hardware Fault 17: Motor-to-ground Short Circuit 18: Motor Identification Error 19: Motor Off-load 20: PID Feedback Loss 21: User Customized Fault 1 22: User Customized Fault 2 23: Power-on Time Arrival 24: Running Time Arrival 25: Encoder Fault 26: Parameter Read-Write Abnormity 27: Motor Overheat 28: Larger Speed Deviation 29: Motor Over-speed 30: Initial Position Error 31: Current Detection Fault 32: Contactor 33: Abnormity of Current Detection 34: Fast Current-limiting Timeout 35: Motor Switch at Running 36~39: Reserved 40: Buffer Resistance Fault		●
P6. 0. 03	Fault Frequency 1			●
P6. 0. 04	Fault Current 1			●
P6. 0. 05	Bus Voltage 1 when at Fault			●
P6. 0. 06	Input Terminal State 1 when at fault			●

Chapter VI Functional Parameters Table

Function code	Function name	Setting scope	Factory value	Modification limit
P6. 0. 07	Output Terminal State 1 when at fault			●
P6. 0. 08	Frequency drive State 1 when at fault			●
P6. 0. 09	Power-on Time 1 when at fault			●
P6. 0. 10	Running Time 1 when at fault			●
P6. 0. 11	Fault Frequency 2			●
P6. 0. 12	Fault Current 2			●
P6. 0. 13	Bus Voltage 2 when at Fault			●
P6. 0. 14	Input Terminal State 2 when at fault			●
P6. 0. 15	Output Terminal State 2 when at fault			●
P6. 0. 16	Frequency drive State 2 when at fault			●
P6. 0. 17	Power-on Time 2 when at fault			●
P6. 0. 18	Running Time 2 when at fault			●
P6. 0. 19	Fault Frequency 3			●
P6. 0. 20	Fault Current 3			●
P6. 0. 21	Bus Voltage 3 when at Fault			●
P6. 0. 22	Input Terminal State 3 when at fault			●
P6. 0. 23	Output Terminal State 3 when at fault			●
P6. 0. 24	Frequency drive State 3 when at fault			●
P6. 0. 25	Power-on Time 3 when at fault			●
P6. 0. 26	Running Time 3 when at fault			●
Group 6.1: Protection Control Group				
P6. 1. 00	Input Default Phase Protection	0: Prohibited 1: Allowed	0	☆
P6. 1. 01	Output Default Phase Protection	0: Prohibited 1: Allowed	1	☆
P6. 1. 02	Over-voltage Stall Protection Sensitivity	0~100	5	☆
P6. 1. 03	Over-voltage Stall Protection Voltage Point	120%~150%	130	☆
P6. 1. 04	Over-current Stall Protection Sensitivity	0~100	020	☆
P6. 1. 05	Over-current Stall Protection current	100%~200%	150	☆
P6. 1. 06	Fault Auto Reset Number	0~20	00	☆
P6. 1. 07	Waiting Interval Time of Fault Auto Reset	0. 1s~100. 0s	10. 0	☆
P6. 1. 08	Fault Protective Action Selection 1	0: Free Stop 1: Stop by its Mode 2: Continuous Running Ones: Motor Overload Tens: Input Default Phase Hundreds: Output Default Phase Thousands: External Default Ten Thousands: Communication Abnormality	00000	☆

Chapter VI Functional Parameters Table

Function code	Function name	Setting scope	Factory value	Modification limit
P6. 1. 09	Fault Protective Action Selection 2	0: Free Stop 1: Stop by its Mode 2: Continuous Running Ones: Motor Overload Tens: Feedback Loss Hundreds: User Customized Fault 1 Thousands: User Customized Fault 2 Ten Thousands: Power-on Time Arrival	00000	★
P6. 1. 10	Fault Protective Action Selection 3	Ones: Running Time Arrival 0: Free Stop 1: Stop by its Mode 2: Continuous Running Tens: Encoder Abnormality 0: Free Stop Hundreds: Parameter Read-Write Abnormity 0: Free Stop 1: Stop by its Mode Thousands: Motor Overhear 0: Free Stop 1: Stop by its Mode 2: Continuous Running Ten Thousands: Fault of 24V Power Supply 0: Free Stop 1: Stop by its Mode	00000	☆
P6. 1. 11	Fault Protective Action Selection 4	0: Free Stop 1: Stop by its Mode 2: Continuous Running Ones: Larger Speed Deviation Tens: Motor Over-speed Hundreds: Initial Position Error Thousands: Reserved Ten Thousands: Reserved	00000	☆
P6. 1. 12	Continuous Running Frequency Selection when at Fault	0: Running at Current Frequency 1: Running at Reference frequency 2: Running at Upper Frequency 3: Running at Lower Frequency 4: Running at Back Frequency for Abnormality	0	☆
P6. 1. 13	Backup Frequency for Abnormality	000.0%~100.0%	100. 0	☆
P6. 1. 14	Action Selection for Momentary Interruption	0: Invalid 1: Deceleration 2: Stop by Deceleration	0	☆
P6. 1. 15	Judgment Time of Momentary Interruption Voltage Recovery	000.00s~100.00s	000. 50	☆
P6. 1. 16	Voltage Judgment for	60.0%~100.0% (Standard Bus Voltage)	080. 0	☆

Chapter VI Functional Parameters Table

Function code	Function name	Setting scope	Factory value	Modification limit
	Momentary Interruption Action			
P6. 1. 17	Voltage Judgment for Suspension of Momentary Action	80.0%~100.0% (Standard Bus Voltage)	090. 0	☆
P6. 1. 18	Off-load Protection Selection	0: Invalid 1: Valid	0	☆
P6. 1. 19	Off-load Detection Level	000.0%~100.0%	010. 0	☆
P6. 1. 20	Off-load Detection Time	00.0s~60.0s	01. 0	☆
P6. 1. 21 ~ P6. 1. 24	Reserved	--	--	--
P6. 1. 25	Fault Output Terminal Action Selection during Fault Auto Reset Period	0: No Action 1: Action	0	☆
P6. 1. 26	Input Default Phase Protection Sensitivity	01~10 (The smaller it is, the more sensitivity it is)	05	☆
Group P6.2: Specific function of PV				
P6. 2. 00	PV water pump mode	0: Variable frequency speed adjustment mode 1: CVT mode 2: MPPT mode	2	★
P6. 2. 01	Running status	Ten-thousands place:(0~2) 0: VF mode 1: CVT mode 2: MPPT mode Ones place:(0~6) 0: Shutdown 1: Running 2: Sleep 3: Low-frequency protection 4: Drying protection in process 5: Overcurrent protection 6: Min. power protection	Read only	●
P6. 2. 02	VOC voltage	0.0V~999.9V	Read only	●
P6. 2. 03	CVT target voltage	30.0%~102.4%	81.0%	☆
P6. 2. 04	MPPT voltage upper limit	0.0V~1000.0V	1000.0V	★
P6. 2. 05	MPPT voltage lower limit	0.0V~1000.0V	500.0V	★
P6. 2. 06	MPPT adjustment interval	0.01s~60.00s	2.00s	☆
P6. 2. 07	MPPT slide search	0.01s~60.00s	0.50s	☆
P6. 2. 08	MPPT initial voltage	30.0%~102.4%	97.0%	☆
P6. 2. 09	Threshold of fast frequency rise	0.00Hz/s -50.00 Hz/s	2.00Hz/s	☆
P6. 2. 10	Threshold of fast frequency drop	0.00Hz/s -50.00 Hz/s	30.00Hz/s	☆
P6. 2. 11	Threshold of sleep	0-1000V	0V	★

Chapter VI Functional Parameters Table

Function code	Function name	Setting scope	Factory value	Modification limit
	voltage			
P6. 2. 12	Sleep recovery voltage	0-1000V	400V	★

Function code	Function name	Setting scope	Factory value
P6. 2. 13	Sleep shutdown wait time	0.0-6000.0s	20.0s
P6. 2. 14	Low-frequency protection detection frequency	0.00Hz-50.00Hz	0.00Hz
P6. 2. 15	Low-frequency protection detection period	0.0-6000.0s	60.0s
P6. 2. 16	Auto recovery time of low-frequency protection	0.0-6000.0s	120.0s
P6. 2. 17	Drying protection detection current	0.00-600.00A	0.00A
P6. 2. 18	Drying protection detection period	0.0-6000.0s	10.0s
P6. 2. 19	Auto recovery time of drying protection	0.0-6000.0s	20.0s
P6. 2. 20	Detection current of customized overcurrent protection	0.0A~600.0A	0.0A
P6. 2. 21	Detection time of customized overcurrent protection	0.0s~6000.0s	10.0s
P6. 2. 22	Auto recovery time of customized overcurrent protection	0.0s~6000.0s	20.0s
P6. 2. 23	Protection value of min. power	0.0kw~1000.0kw	0.0kw
P6. 2. 24	Detection time of min. power protection	0.0s~6000.0s	10.0s
P6. 2. 25	Auto recovery period of min. power protection	0.0s~6000.0s	10.0s
P6. 2. 26	Alarm recovery mode	0: Auto recovery 1: Manual recovery Ones place: Low-frequency protection Tens place: Drying protection Hundreds place: Overcurrent and overload protection Thousands place: Min. power protection	H.0000
P6. 2. 27	Detection time of full water protection	0.0s~6000.0s	10.0s
P6. 2. 28	Quit time of full water protection	0.0s~6000.0s	10.0s
P6. 2. 29	CVT integral gain	0 ~ 65535	2000
P6. 2. 30	CVT proportional gain	0 ~ 65535	300
P6. 2. 31	CVT transition frequency	3.00Hz-50.00Hz	10.00Hz

Chapter VI Functional Parameters Table

P6. 2. 32	Power curve 0	0.00kw~100.00kw	0.50kw
P6. 2. 33	Power curve 1	0.00kw~100.00kw	1.00kw
P6. 2. 34	Power curve 2	0.00kw~100.00kw	1.50kw
P6. 2. 35	Power curve 3	0.00kw~100.00kw	2.00kw
Function code	Function name	Setting scope	Factory value
P6. 2. 36	Power curve 4	0.00kw~100.00kw	2.50kw
P6. 2. 37	Flow curve 0	0.0m ³ /h~1000.0m ³ /h	0.0m ³ /h
P6. 2. 38	Flow curve 1	0.0m ³ /h~1000.0m ³ /h	5.0m ³ /h
P6. 2. 39	Flow curve 2	0.0m ³ /h~1000.0m ³ /h	10.0m ³ /h
P6. 2. 40	Flow curve 3	0.0m ³ /h~1000.0m ³ /h	15.0m ³ /h
P6. 2. 41	Flow curve 4	0.0m ³ /h~1000.0m ³ /h	20.0m ³ /h
P6. 2. 42	Flow calculation offset	0.00m ³ /h~100.00m ³ /h	0.00 m ³ /h
P6. 2. 43	Flow calculation calibration gain	0.0m ³ /h~1000.0m ³ /h	100.0m ³ /h
P6. 2. 44	Daily flow/electric quantity clear period	0.0h~24.0h	7.0h
P6. 2. 45	Photovoltaic start protection	0~1	1
P6. 2. 46	Selection of motor input mode	0: 3-phase input mode of standard motor 1: Single-phase input mode of standard motor 2: Reserved	0
P6. 2. 47	Coefficient of balance of single-phase motor (3-phase output)	0.000~2.000	1.000
P6. 2. 48	MPPT blind area search threshold value	0.0V/Hz~100.0V/Hz	10.0V/Hz
P6. 2. 49	MPPT hysteresis adjustment threshold value	0.00~10.00Hz	0.50Hz
P6. 2. 50	MPPT voltage adjustment stepping	0.0V~30.0V	1.0V
P6. 2. 51	MPPT reference upgrading threshold value	0.0V~300.0V	30.0V
P6. 2. 52	Reserved	0.0~100.0	75.0
P6. 2. 53	Overvoltage protection Detection voltage	750.0V~950.0V	900.0V
P6. 2. 54	Reserved	0~2	0
P6. 2. 55	Enabled after power failure	0: Disabled 1: Restart after power failure	1
P6. 2. 56	Delay of restart after power failure	0.0~6000.0s	10.0s
P6. 2. 57	Wait time of AC/DC mode switching	0.0~6000.0s	5.0s

Chapter VI Functional Parameters Table

P6.2.58	Wait time of DC/AC mode switching	0.0~6000.0s	5.0s
P6.2.59	Select PV input and power frequency input	0: Auto switching mode 1: Power frequency input mode 2: PV input mode	1
Function code	Function name	Setting scope	Factory value
P6.2.60	Reserved	0~1024	64
P6.2.61	Pump cleaning function	0: Disabled 1: Enabling (valid for the current time only)	0
P6.2.62	Cleaning frequency	0.00Hz~50.00Hz	10.00Hz
P6.2.63	Cleaning running duration per cycle	0.0~6000.0s	10.0s
P6.2.64	Cleaning cycles	0~1000	5
P6.2.65	Cleaning ending selection	0: Shutdown 1: Auto running	0
P6.2.66	Timing function selection	0: Invalid 1: Valid (min) 2: Valid (hour)	0
P6.2.67	Running time of timer function	0.0~6500.0min/hour	0.0
P6.2.68	Times of automatic fault resetting	0~100	000
P6.2.69	CVT gain Switching voltage	0.0V~100.0V	20.0V
P6.2.70	CVT Integral gain 2	0~65535	1000
P6.2.71	CVT proportional gain 2	0~65535	50

6.8 Group P8 - Manufacturer Function

Function code	Function name	Setting scope	Factory value	Modification limit
P8.0.00	Manufacturer Code	00000~65535	00000	☆
Group P8.1: Calibrate parameter group				
P8.1.00	Voltage Input of Potentiometer Correction Point 1	00.00V~P8.1.02	00.00	☆
P8.1.01	Corresponding reference of Potentiometer Correction Point 1	-100.0%~100.0%	000.0	☆
P8.1.02	Voltage Input of Potentiometer Correction Point 2	P8.1.00~10.00V	10.00	☆
P8.1.03	Corresponding reference of Potentiometer Correction Point 2	-100.0%~100.0%	100.0	☆
P8.1.04	Filtering time of potentiometer	00.00s~10.00s	00.10	☆
P8.1.05	VF1 actual voltage 1	0.500V~4.000V	2.000	☆
P8.1.06	VF1 indicated voltage 1	0.500V~4.000V	2.000	☆
P8.1.07	VF1 actual voltage 2	6.000V~9.999V	8.000	☆
P8.1.08	VF1 indicated voltage 2	6.000V~9.999V	8.000	☆
P8.1.09	VF2 actual voltage 1	0.500V~4.000V	2.000	☆
P8.1.10	VF2 indicated voltage 1	0.500V~4.000V	2.000	☆

Chapter VI Functional Parameters Table

P8.1.11	VF2 actual voltage 2	6.000V~9.999V	8.000	☆
P8.1.12	VF2 indicated voltage 2	6.000V~9.999V	8.000	☆
P8.1.13	FM1 target voltage 1	0.500V~4.000V	2.000	☆
P8.1.14	FM1 actual voltage 1	0.500V~4.000V	2.000	☆
P8.1.15	FM1 target voltage 2	6.000V~9.999V	8.000	☆
P8.1.16	FM1 target voltage 2	6.000V~9.999V	8.000	☆
P8.1.17 ~ P8.1.20	Reserved	---	--	--

6.9 Group P9 - Monitoring Parameter

Function code	Function name	Setting scope	Factory value
P9.0.00	Running frequency	Output frequency of running frequency drive	0.01Hz
P9.0.01	Input frequency	Input frequency of frequency drive	0.01Hz
P9.0.02	Output current	Output current of running frequency drive	0.01A
P9.0.03	Output voltage	Output voltage of running frequency drive	1V
P9.0.04	Busbar voltage	Voltage of DC busbar of frequency drive	0.1V
P9.0.05	Output torque	Output torque of running frequency drive, percentage of motor rated torque	0.1%
P9.0.06	Output power	Output power of running frequency drive	0.1kW
P9.0.07	Input terminal status	Check whether input terminal has signal input	
P9.0.08	Output terminal status	Check whether output signal has signal output	
P9.0.09	VF1 voltage	Check the voltage between VF1 and GND	0.01V
P9.0.10	VF2 voltage	Check voltage between VF2 and GND	0.01V
P9.0.11	Customized display value	The converted value of customized display value P5.0.15 and customized display decimal point P5.0.16	
P9.0.12	Actual counting	Check the actual counting of frequency drive for counting function	1
P9.0.13	Actual length	Check the actual length of frequency drive for fixed-length function	1m
P9.0.14	Given PID	Product of PID set value and PID set feedback range	
P9.0.15	PID feedback	Product of PID feedback and PID set feedback range	
P9.0.16	Reserved	--	--
P9.0.17	Feedback velocity	Actual output frequency of running frequency drive	0.1Hz
P9.0.18	PLC stage	Display the running stage of simple PLC	1
P9.0.19	VF1 voltage prior to calibration	Voltage between VF1 and GND prior to VF1 calibration	0.001V
P9.0.20	VF2 voltage prior to calibration	Voltage between VF2 and GND prior to VF2 calibration	0.001V
P9.0.21	Reserved	--	--

Chapter VI Functional Parameters Table

P9.0.22	Current power-on period	The current power-on period	1min
P9.0.23	Current running period	The current running period	0.1min
P9.0.24	Residual running period	Residual running period of P3.1.00 timing function	0.1min
P9.0.25	Frequency of frequency source A	Check frequency given by frequency source A	0.01Hz
P9.0.26	Frequency of frequency source B	Check frequency given by frequency source B	0.01Hz
Function code	Function name	Setting scope	Factory value
P9.0.27	Given value of communication	Value of corresponding communication address A001, percentage of the highest frequency	%
P9.0.28 ~ P9.0.49	Reserved	--	--
P9.0.50	Flow per day	View daily flow value	
P9.0.51	Cumulative total flow(low position)	View low order of total flow	
P9.0.52	Cumulative total flow(high position)	View high order of total flow	
P9.0.53	Generated power per day	View daily generating capacity	
P9.0.54	Cumulative total power consumption (low position)	View low order of total electricity	
P9.0.55	Cumulative total power consumption (high position)	View high order of total electricity	

Chapter VI Functional Parameters Table

Chapter VII Parameters

Chapter VII Parameters

7.1 Fault Display and Protection P6 Group

Function Code	Name	Set Range	Default Value	Change Restriction
P6.2.00	PV water pump mode	0: Variable-frequency speed regulation mode 1: CVT mode 2: MPPT mode	2	★

0: General inverter mode

1: CTV mode, constant-voltage mode; reference voltage is a fixed value and set via P6.2.03 keyboard.

2: MPPT mode, max. power tracking mode, reference voltage is set via the max. power tracking algorithm; this reference voltage will change constantly until the system is stabilized.

Function Code	Name	Set Range	Default Value	Change Restriction
P6.2.01	Running status	0: Shutdown mode 1: Running mode 2: Sleep mode 3: Low frequency protection 4: Dry running protection 5: Overcurrent protection 6: Min. power protection	Read only	●

Display the current running status of drive.

Function Code	Name	Set Range	Default Value	Change Restriction
P6.2.02	VOC voltage	0.0V~999.9V	Read only	●

Open-circuit busbar voltage, i.e. busbar voltage at no-load status or drive shutdown status.

Function Code	Name	Set Range	Default Value	Change Restriction
P6.2.04	MPPT voltage upper limit	0.0V~1000.0V	1000.0V	★
P6.2.05	MPPT voltage lower limit	0.0V~1000.0V	0.0V	★

Enter MPPT mode, search the upper/lower limit amplitude of voltage at max. power point.

Function Code	Name	Set Range	Default Value	Change Restriction
P6.2.06	MPPT control interval	0.01s~60.00s	2.00s	☆
P6.2.07	MPPT slide search	0.01s~60.00s	0.50s	☆

Enter MPPT mode, search control interval of voltage at max. power point and search voltage filtering time of neutral busbar.

Chapter VII Parameters

When the two parameters are high, the voltage fluctuation of searched max. power point will decrease and the response will slow down.

When the two parameters are low, the voltage fluctuation of searched max. power point will increase and the response will speed up. No alternation is recommended, for the default value can satisfy most requirements.

Function Code	Name	Set Range	Default Value	Change Restriction
P6.2.08	MPPT initial voltage	30.0%~102.4%	97.0%	☆

The set voltage at initial status in MPPT mode. This reference voltage will change constantly, until the system is stabilized. The target frequency will change towards the upper limit of PI output frequency when busbar voltage is higher than the reference voltage, regardless of the mode of reference voltage; when busbar voltage is lower than the reference voltage, the target frequency will change towards the lower limit of PI output frequency.

Function Code	Name	Set Range	Default Value	Change Restriction
P6.2.09	Threshold of fast frequency increase	0.00Hz/s -50.00 Hz/s	1.00Hz/s	☆

Upper threshold of frequency change outputted by PID adjustment algorithm.

Function Code	Name	Set Range	Default Value	Change Restriction
P6.2.10	Threshold of fast frequency decrease	0.00Hz/s -50.00 Hz/s	30.00Hz/s	☆

Lower threshold of frequency change outputted by PID adjustment algorithm.

Function Code	Name	Set Range	Default Value	Change Restriction
P6.2.29	CVT integral gain	0 ~ 65535	2000	☆
P6.2.30	CVT proportional gain	0 ~ 65535	100	☆

Proportion and integral gain of PID adjustment algorithm

Function Code	Name	Set Range	Default Value	Change Restriction
P6.2.11	Sleep voltage threshold	0-1000V	0V	★
P6.2.12	Sleep recovery voltage	0-1000V	400V	★
P6.2.13	Wait time of sleep shutdown	0.0-6000.0s	20.0s	★

While PV water pump is running, the inverter will enter sleep mode and keyboard will show alarm “Err60” when DC voltage provided by solar panel is lower than P6.2.11 (sleep voltage threshold); the inverter will start running after passing the time of P6.2.13 (wait time of sleep shutdown) when DC voltage of solar panel is recovered to the value of P6.2.12 (sleep recovery voltage).

Function	Name	Set Range	Default Value	Change
----------	------	-----------	---------------	--------

Chapter VII Parameters

Code				Restriction
P6.2.14	Detection frequency of low frequency protection	0.00-300.00Hz	0.00H z	☆
P6.2.15	Detection time of low frequency protection	0.0-6000.0s	10.0s	★
P6.2.16	Auto recovery time of low-frequency protection	0.0-6000.0s	20.0s	★

While PV water pump is running, protection standby mode will be enabled and keyboard will show alarm “Err61” when output frequency is lower than P6.2.14 (detection frequency of low frequency protection) and lasts for the period of P6.2.15 (detection time of low frequency protection) due to certain reason; when protection standby mode is entered, it will recover auto running after passing the time of P6.2.16 (auto recovery time of low frequency protection).

Function Code	Name	Set Range	Default Value	Change Restriction
P6.2.17	Detection current of dry running protection	0.00-600.00A	0.00A	★
P6.2.18	Detection time of dry running protection	0.0-6000.0s	10.0s	★
P6.2.19	Auto recovery time of dry running protection	0.0-6000.0s	20.0s	★

While PV water pump is running, protection standby mode will be enabled and keyboard will show alarm “Err62” when output current is lower than P6.2.17 (detection frequency of dry running protection) and lasts for the period of P6.2.18 (detection time of dry running protection) due to certain reason; when protection standby mode is entered, it will recover auto running after passing the time of P6.2.19 (auto recovery time of dry running protection).

Function Code	Name	Set Range	Default Value	Change Restriction
P6.2.20	Detection current of defined overcurrent protection	0.00A~600.00A	0.00A	★
P6.2.21	Detection time of defined overcurrent protection	0.0s~6000.0s	10.0s	★
P6.2.22	Auto recovery time of defined overcurrent protection	0.0s~6000.0s	20.0s	★

While PV water pump is running, protection standby mode will be enabled and keyboard will show alarm “Err63” when output current is higher than P6.2.20 (detection current of overcurrent protection) and lasts for the period of P6.2.21 (detection time of overcurrent protection) due to certain reason; when protection standby mode is entered, it will recover auto running after passing the time of P6.2.22 (auto recovery time of overcurrent protection).

Chapter VII Parameters

Function Code	Name	Set Range	Default Value	Change Restriction
P6.2.23	Min. power protection value	0.0kw~1000.0kw	0.0kw	★
P6.2.24	Detection time of min. power protection	0.0s~6000.0s	10.0s	★
P6.2.25	Auto recovery time of min. power protection	0.0s~6000.0s	10.0s	★

While PV water pump is running, protection standby mode will be enabled and keyboard will show alarm “Err64” when output power is lower than P6.2.23 (min. power protection value) and lasts for the period of P6.2.24 (detection time of min. power protection) due to certain reason; when protection standby mode is entered, it will recover auto running after passing the time of P6.2.25 (auto recovery time of min. power).

Function Code	Name	Set Range	Default Value	Change Restriction
P6.2.26	Alarm recovery mode	0: Auto recovery; 1: Manual recovery Ones unit: Low frequency protection Ten’s place: Dry running protection Hundred’s place: Overcurrent & overload protection Thousand’s place: Min. power protection	H.0000	★

The options apply to low frequency protection function, dry running protection function, overcurrent protection function and min. power function; the alarm recovery mode can be selected through P6.2.26. During the period of auto recovery and fault alarm display, the pump can also be stopped by pressing “STOP” key when the function code is selected as 0. During the period of fault display, the fault can be cleared manually by pressing “STOP” button to realize shutdown when this function code is selected as 1.

Function Code	Name	Set Range	Default Value	Change Restriction
P6.2.27	Detection time of full water protection	0.0s~6000.0s	10.0s	★
P6.2.28	Quit time of full water protection	0.0s~6000.0s	10.0s	★

Realize auto control over water level by detecting the full water alarm level and low water level through Terminal DI3; in which, P6.2.27 is detection time of full water protection, P6.2.28 is quit time of full water protection, Terminal DI3 is input of PV full water detection and alarm signal, and the alarm signal is “Err65”.

Function Code	Name	Set Range	Default Value	Change Restriction
P6.2.32	Power curve 0	0.00kw~100.00kw	0.50kw	★
P6.2.33	Power curve 1	0.00kw~100.00kw	1.00kw	★
P6.2.34	Power curve 2	0.00kw~100.00kw	1.50kw	★

Chapter VII Parameters

P6.2.35	Power curve 3	0.00kw~100.00kw	2.00kw	★
P6.2.36	Power curve 4	0.00kw~100.00kw	2.50kw	★
P6.2.37	Flow curve 0	0.0m ³ /h~1000.0m ³ /h	0.0m ³ /h	★
P6.2.38	Flow curve 1	0.0 m ³ /h~1000.0m ³ /h	5.0m ³ /h	★
P6.2.39	Flow curve 2	0.0 m ³ /h~1000.0m ³ /h	10.0m ³ /h	★
P6.2.40	Flow curve 3	0.0 m ³ /h~1000.0m ³ /h	15.0m ³ /h	★
P6.2.41	Flow curve 4	0.0 m ³ /h~1000.0m ³ /h	20.0m ³ /h	★
P6.2.44	Clear period of daily flow/electric quantity	0.0h~24.0h	7.0h	★

This pump provides defined PQ curve; so, the user can set 5 groups of PQ points based on the conditions of pump, in order to calculate the real-time flow speed, daily flow, accumulated flow, daily generating capacity and accumulated power consumption, in which, the daily flow and generating capacity are calculated based on the period of 7h as one day by default.

Function Code	Name	Set Range	Default Value	Change Restriction
P6.2.55	Enable restart after power failure	0: Disable 1: Restart after power failure	1	☆
P6.2.56	Delay of restart after power failure	0.0~6000.0s	10.0s	★

When drive is powered off due to low DC busbar voltage of drive and then busbar voltage reaches the working voltage again, this function can realize whether restart the drive and set the start delay time. This function will be effective only if running mode (P0.0.3) is set as 0 (keyboard control).

Function Code	Name	Set Range	Default Value	Change Restriction
P6.2.57	Wait time of AC-DC switch	0.0~6000.0s	300.0s	★
P6.2.58	Wait time of DC-AC switch	0.0~6000.0s	5.0s	★

Set parameters of AC/DC mode switch. External AC/DC module is required additionally.

Function Code	Name	Set Range	Default Value	Change Restriction
P6.2.59	Select PV input and power frequency input	0: Auto switch mode 1: Power frequency input mode 2: PV input mode	2	★

When this function code is selected as 0, the system will have auto switch between power supply of power frequency and PV board through external relay based on detected status of DI terminal.

When this function code is selected as 1, the system will switch to power frequency input by force.

When this function code is selected as 2, the system will switch to PV input by force.

Chapter VII Parameters

Function Code	Name	Set Range	Default Value	Change Restriction
P6.2.61	Enable cleaning	0: Disabled 1: Enabled (valid in single time only)	0	★
P6.2.62	Cleaning frequency	0.00Hz~50.00Hz	10.00Hz	☆
P6.2.63	Running period of single cleaning	0.0~6000.0s	10.0s	★
P6.2.64	Cleaning times	0~1000	5	★
P6.2.65	Select cleaning completion	0: Shutdown 1: Auto running	0	★
P6.2.66	Select timing function	0: Disabled 1: Enabled (min) 2: Enabled (hour)	0	★
P6.2.67	Timing running period	0.0~6500.0min/hour	0.0	★
P6.2.68	Auto reset times of fault	0~100	000	☆

Auto cleaning function and timing running function of water pump. This is customized function group for customer.

Chapter VIII RS-485 Communication

1. Introduction to SPD Series Variable Frequency RS-485 Communication Terminal

Control board of SPD series (30kW and higher) frequency converter is fitted with RS-485 communication terminal.

SG+: 485 positive end of signal

SG-: 485 negative end of signal

The communication extension card must be used for enabling the communication function, for the control board of SPD series (0.4kW~22kW) frequency converter has no RS-485 communication terminal.

2. Explanation for SPD series frequency inverter Communication Parameter

"The RS-485 communication terminal isn't equipped. The external communication expansion card must be connected to realize communication. The "Baud Rate", "Data Format" and "Communication Address" of frequency inverter must be set via the keyboard.

Function Code	Function Name	Setting Scope	Factory Value
P4.1.00	Baud Rate	Ones: 0: 1200 1: 2400 2: 4800 3: 9600 4: 19200 5: 38400 6: 57600	03
P4.1.01	Data Format	0: No Check (8-N-2) 1: Even Parity Check (8-E-1) 2: Odd Parity Check (8-O-1) 3: No Check (8-N-1)	0
P4.1.02	Local Machine Address	000 is Broadcast Address 001~249	1
P4.1.03	Response Delay	0ms ~ 20ms	2
P4.1.04	Communication Timeout	0.0(Invalid) 0.1s ~ 60.0s	0.0
P4.1.05	Data Transmission Format	Ones: 0: ASCII mode (Reserved) 1: RTU mode	01

Response Delay: when the frequency inverter receives the data and after the time set by Function Code P4.1.03 is delayed, the frequency inverter starts recovering the data.

Chapter VIII RS-485 Communication

Communication Timeout: the interval between data frames received by the frequency inverter is over the time set by Function Code P4.1.04, the frequency inverter gives an alarm of Fault Err14, it is deemed as abnormal communication. If it is set at 0.0, the communication timeout is invalid.

3. Description for Standard MODBUS Communication Format

3.1 String Structure

(8-N-2, P4.1.01=0)

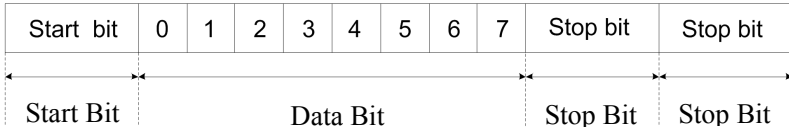

(8-SPD-1, P4.1.01=1)

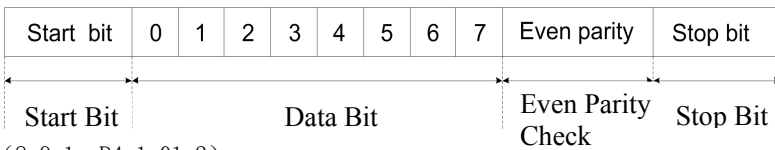

(8-0-1, P4.1.01=2)



(8-N-1, P4.1.01=3)

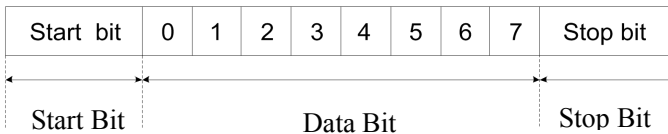

3.2 Communication Data Structure

Chapter IX Fault Handling

ADR	Slave Machine (Frequency inverter) Address The address scope of the frequency inverter is (001~249), (8-digit hexadecimal number) Note: When the address is ADR=000H, it is valid for all slave machines and all slave machines can't respond message (broadcast mode)
CMD	Function Code of Data Package (06: write the contents of a register; 03: read out the contents of one or more than one register(s)) (8-digit hexadecimal number)
ADRE SS	Sending of Host Machine: when at Function Code 06, it means data address (16-digit hexadecimal number); when at Function Code 03, it means data initial address (16-digit hexadecimal number) Slave Station Responds: refer to data address when at function code 06 (16-digit hexadecimal number); refer to data number when at function code 03 (8-digit hexadecimal number)
DATA	Sending of Host Machine: when at Function Code 06, it means data address (16-digit hexadecimal number); when at Function Code 03, it means data initial address (16-digit hexadecimal number) Slave Station Responds: when at Function Code 06, it means data address (16-digit hexadecimal number); when at Function Code 03, it means data initial address (16-digit hexadecimal number in N)
CRC	CHK (CHECKSUM) (16-digit hexadecimal number)

RTU adopts CRC CHK (CHECKSUM), which is calculated as the following steps:

Step 1: Load 16-digit register with content of FFFFH (CRC Register).

Step 2: Conduct XOR operation for the first byte of the communication data and the contents of CRC Register and store the results into CRC Register.

Step 3: Move 1bit of the contents of CRC Register to the minimum significant bit and fill in 0 to the maximum significant bit, and check the minimum significant bit of CRC Register.

Step 4: If the minimum significant bit is 1, the CRC Register and preset value conduct XOR operation. If the minimum significant bit is 0, no action is taken.

Step 5: After repeat 8 times of Step 3 and 4, the handling to this byte is finished.

Step 6: Repeat Step 2-5 for next byte of the communication data until the handling to all bytes are completed, the final content of CRC Register is the value of CRC.

When transmitting CRC Value, first add the low byte and then high byte, that is, the low byte is first transmitted.

In case of any fault of the communication, the slave machine responds the data of

Chapter VIII RS-485 Communication

ADDRESS and DATA as below:

ADDRESS	DATA	Description	ADDRESS	DATA	Description
FF01	0001	Invalid address	FF01	0005	Invalid parameter
FF01	0002	CRC Check Error	FF01	0006	Invalid Modification to Parameter
FF01	0003	Read and Write Command Error	FF01	0007	System Lock
FF01	0004	Password Error	FF01	0008	Parameter under Storage

The master station writes the command string format:

Name of Character Length of Character Example	Slave Station	Write Command 06H	Function Code Address	Data content	CRC Check
	1Byte	1Byte	2Byte	2Byte	2Byte
	01H	06H	0005H	1388H	949DH

The slave station responds the command string format:

Name of Character Length of Character Example	Slave Station	Write Command 06H	Function Code Address	Data content	CRC Check
	1Byte	1Byte	2Byte	2Byte	2Byte
	01H	06H	0005H	1388H	949DH

The master station reads the command string format:

Name of Character Length of Character Example	Slave Station	Read Command 03H	Initial Address of Function Code	Data content	CRC Check
	1Byte	1Byte	2Byte	2Byte	2Byte
	01H	03H	9000H	0003H	28CBH

The slave station responds the read command string format:

Name of Character Length of Character Example	Slave Station	Read Command 03H	Data content	Data content 1	Data content 2	Data content 3	CRC Check
	1Byte	1Byte	1Byte	2Byte	2Byte	2Byte	2Byte
	01H	03H	06H	0000H	0000H	0000H	2175H

The slave station responds the write command error string format:

Name of Character Length of Character Example	Slave Station	Write Command 06H	Read and Write Error Mark	Read and Write Error Type	CRC Check
	1Byte	1Byte	2Byte	2Byte	2Byte
	01H	06H	FF01H	0005H	281DH

Chapter IX Fault Handling

The slave station responds the read command error string format:

Name of Character	Slave Station	Read Command 03H	Read and Write Error Mark	Read and Write Error Type	CRC Check
Length of Character	1Byte	1Byte	2Byte	2Byte	2Byte
Example	01H	03H	FF01H	0005H	E41DH

4. Definition for Parameter Address of Communication Protocol

The SPD series frequency inverter not only has many multifunctional function code parameters, but some non- multifunctional function code parameters. Specific read and write properties are as below:

Function Code Parameter	P1~P8	Readable, writable
	P9	Only Readable
Non-function Code Parameter	A000H、A001H、A002H、A003H、A004H、A005H、A010H、A011H	Only writable
	B000H、B001H	Only Readable

Explanation for Read and Write Address of Function Code Parameters:

High-order parameter address is composed of groups and levels by the function code parameters. For the service life of EEPROM is limited, the EEPROM cannot be stored frequently in the process of communication. Therefore, some function codes don't need to be stored in EEPROM in the process of communication, but only need to modify the value in RAM.

If it is required to write them into EEPROM, the high-order parameter address adopts the hexadecimal number and low parameter address adopts decimal number that then is converted to the hexadecimal number. And then the high-order and low-order parameter address constitutes a four-digit hexadecimal number.

For example: the address of writing P2.1.12 to EEPROM is as below:

High-order address is 21 by hexadecimal system, and lower-order address is 12 by decimal system, which is 0C after conversion into hexadecimal system, so the address indicates 0x210C.

If it is not required to write it into EEPROM, the high-order parameter address adopts hexadecimal number and adds 4 digits, and low-order parameter address adopts decimal number then is converted to the hexadecimal number. And then the high-order and low-order parameter address constitutes a four-digit hexadecimal number.

For example: the address of not writing P2.1.12 to EEPROM is as below:

High-order address is 21 by hexadecimal system and then adds 4 digits, that is, 25. The lower-order address is 12 by decimal system, which is 0C after conversion into hexadecimal system, so the address indicates 0x250C.

Table of Definitions for Non-functional Function Code Parameter Address

Chapter VIII RS-485 Communication

Definition	Function Code	Parameter Address	Description for Function	
Command to frequency inverter	06H	A000H	0001H	Forward Run
			0002H	Reverse Run
			0003H	Forward Jogging
			0004H	Reverse Jogging
			0005H	Free Stop
			0006H	Shutdown By Speed Reduction
			0007H	Fault Rest
		A001H	Frequency Command or Upper Frequency Source (refer to the percentage of the highest frequency without storage) (00.00~100.00 indicates 00.00%~100.00%)	
		A002H	BIT2	T1 relay
			If it is required to make T1 relay signal valid, set corresponding position to 1, after transfer binary system to hexadecimal system, send it to address A002.	
		A003H	FM1 Output Address (00.0~100.0 indicates 00.0%~100.0%)	
	A004H	FM2 Output Address (00.0~100.0 indicates 00.0%~100.0%)		
	A010H	PID Reference Value		
	A011H	PID Feedback Value		
Running status of monitoring frequency inverter	03H	B000H	0001H	Forward Run
			0002H	Reverse Run
			0003H	Stop

Table of Definitions for Non-functional Function Code Parameter Address

Definition	Function Code	Parameter Address	Description for Function	
Monitoring to Fault of Frequency inverter	03H	B001H	00	No fault
			01	Over-current at constant speed
			02	Over-current at acceleration
			03	Over-current at deceleration
			04	Over-voltage at constant speed
			05	Over-voltage at acceleration
			06	Over-voltage at deceleration
			07	Module Fault
			08	Under-voltage
			09	Frequency inverter Overload
			10	Motor Overload
			11	Missing phase
12	Output Default Failure			

Definition	Function	Parameter	Description for Function
------------	----------	-----------	--------------------------

Chapter IX Fault Handling

	Code	Address		
			13	External Fault
			14	Abnormal Communication
			15	Frequency inverter Overheat
			16	Hardware Fault of Frequency inverter
			17	Motor-to-ground short circuit
			18	Motor Identification Error
			19	Motor Off-load
			20	PID Feedback Loss
			21	User-Defined Fault 1
			22	User-Defined Fault 2
			23	Accumulative Power-on Time Reached
			24	Accumulative Running Time Reached
			25	Encoder Fault
			26	Parameter Read-Write Abnormity
			27	Motor Overheat
			28	Larger Speed Deviation
			29	Motor Over-speed
			30	Initial Position Error
			31	Current Detection Fault
			32	Contactors
			33	Abnormity of Current Detection
			34	Fast Current-limiting Timeout
			35	Motor Switch at Running
			36	Power Fault
			37	Driving Power Supply Fault
			38	Output short circuit
			40	Buffer Resistance
			60	Sleep Function
			61	Low-frequency Protection Function
			62	Drying Protection Function
			63	Overcurrent Protection Function
			64	Min. Power Protection Function
			65	Full Water Protection Function

5. Example

Chapter VIII RS-485 Communication

Example 1: Forward Start No.1 Frequency Inverter

The host machine sends data package

ADR	01H
CMD	06H
ADDRESS	A0H
	00H
DATA	00H
	01H
CRC	6AH
	0AH

The slave machine responds the data package

ADR	01H
CMD	06H
ADDRESS	A0H
	00H
DATA	00H
	01H
CRC	6AH
	0AH

Example 2: Reference No.1 Frequency inverter Frequency (Not store)

The frequency value of Reference 1# Frequency inverter is the highest frequency 100.00%.

Methods are as below: after removal of the decimal point of 100.00, it is 10000D=2710H.

The host machine sends data package

ADR	01H
CMD	06H
ADDRESS	A0H
	01H
DATA	27H
	10H
CRC	E0H
	36H

Respond the data package

ADR	01H
CMD	06H
ADDRESS	A0H
	01H
DATA	27H
	10H
CRC	E0H
	36H

Example 3: Inquire the running frequency of No.1 Frequency inverter Frequency

In running state, inquire the “Output Frequency” of the Frequency inverter 1#

Methods are as below: the Function Code Parameter No. of the output frequency is P9.0.00, after conversion into address, it is 9000H.

If the “Output Frequency” of the Frequency inverter 1# is 50.00Hz, it is 5000D=1388H

The host machine sends data package

ADR	01H
CMD	03H
ADDRESS	90H
	00H
DATA	00H
	01H
CRC	A9H
	0AH

The slave machine responds the data package

ADR	01H
CMD	03H
ADDRESS	02H
DATA	13H
	88H
CRC	B5H
	12H

Chapter IX Fault Handling

Chapter IX Fault Handling

Fault display	Description	Details	Fault elimination
Err00	No Fault		
Err01	Over-current at constant speed	The output current exceeds the over-current value while the frequency inverter is running at a constant speed	<ul style="list-style-type: none"> ● Check whether the output circuit of the frequency inverter has short circuit; ● Check whether the input voltage is relatively low; ● Check whether the load has mutation; ● Conduct parameter identification or improve low frequency torque compensation; ● Check whether the rated power of the motor or frequency inverter is large enough;
Err02	Over-current at acceleration	When the frequency inverter accelerates, output current exceeds over-current	<ul style="list-style-type: none"> ● Check whether the motor is and its lines are short circuit, grounded or too long; ● Check whether the input voltage is relatively low; ● Delay the acceleration time; ● Conduct parameter identification or improve low frequency torque compensation or adjust V/F Curve; ● Check whether the load has mutation; ● Check whether it is to select speed tracking or start after the motor stops stably; ● Check whether the rated power of the motor or frequency inverter is large enough;
Err03	Over-current at deceleration	When the frequency inverter decelerates, output current exceeds over-current	<ul style="list-style-type: none"> ● Check whether the motor is and its lines are short circuit, grounded or too long; ● Conduct parameter identification; ● Delay the deceleration time; ● Check whether the input voltage is relatively low; ● Check whether the load has mutation; ● Install additional brake unit and brake resistance;
Err04	Over-voltage at constant speed	When the frequency inverter runs at constant speed, DC voltage of the main circuit exceeds this set value	<ul style="list-style-type: none"> ● Check whether the input voltage is too high; ● Check whether the bus voltage display is normal; ● Check whether the motor is dragged to run by external force in the running process;

Chapter IX Fault Handling

Fault display	Description	Details	Fault elimination
Err05	Over-voltage at acceleration	When the frequency inverter runs at constant speed, DC voltage of the main circuit exceeds this set value. The detected over-voltage value is the same as above.	<ul style="list-style-type: none"> ● Check whether the input voltage is too high; ● Check whether the bus voltage display is normal; ● Delay the deceleration time; ● Check whether the motor is dragged to run by external force in the process of deceleration; ● Install additional brake unit and brake resistance;
Err06	Over-voltage at deceleration	When the frequency inverter runs at constant speed, DC voltage of the main circuit exceeds this set value. The detected over-voltage value is the same as above.	<ul style="list-style-type: none"> ● Check whether the input voltage is too high; ● Check whether the bus voltage display is normal; ● Delay the deceleration time; ● Check whether the motor is dragged to run by external force in the process of deceleration; ● Install additional brake unit and brake resistance;
Err07	Module fault	External fault has triggered automatic module protection	<ul style="list-style-type: none"> ● Check the coil resistance of the motor; ● Check the isolation of the motor; ● Damage by inverse module breakdown;
Err08	Under-voltage	Under-voltage in the main circuit, check the electric level	<ul style="list-style-type: none"> ● Check the lines of supply power contact well; ● Check whether the incoming voltage is within regulated scope; ● Check whether there is momentary interruption; ● Check whether the display of the bus voltage is normal; ● Check whether the setting bridge and charge resistance are normal;
Err09	Frequency inverter overloaded	Motor and current exceed the rated load	<ul style="list-style-type: none"> ● Check whether the motor is in locked-rotor conditions or the load to motor needs to be reduced; ● Replace the frequency inverter with larger power;
Err10	Motor overload	Motor and current exceed the rated current	<ul style="list-style-type: none"> ● Check the protection parameter P1.0.25 Reference of the motor is proper; ● Check whether the motor is in locked-rotor conditions or the load to motor needs to be reduced; ● Correctly preset the rated current of the motor; ● Replace the frequency inverter with larger power;

Chapter IX Fault Handling

Fault display	Description	Details	Fault elimination
Err11	Missing phase	Error of missing phase or unbalanced three phases	<ul style="list-style-type: none"> ● Check main circuit voltage whether it is missing phase or unbalanced three phases; ● Check whether the connecting terminal is loosing; ● Seek technical support;
Err12	Output Default Failure	Output Default Failure or 3-phase Imbalance Fault	<ul style="list-style-type: none"> ● Check whether the output circuit has output default failure or 3-phase imbalance fault; ● Check whether the wiring terminals are loose; ● Seek technical support;
Err13	External Fault	Fault caused by External Control Circuits	<ul style="list-style-type: none"> ● Check the signal input circuit of external fault; ● Reset Run;
Err14	Abnormal Communication	Abnormity for communication of frequency inverter and other equipments	<ul style="list-style-type: none"> ● Check external communication lines ; ● The upper computer doesn't work normally; ● The setting for communication parameter is not correct; ● The communication protocol is inconsistent;
Err15	Frequency inverter Overheat	Radiator temperature \geq oh Detection Value (about 80°C, from temperature switch)	<ul style="list-style-type: none"> ● Check the running state of the fan and ventilation state ; ● Check whether the surrounding temperature is too high and the cooling measures are required to be taken; ● Check whether the thermistor or temperature switch is damaged; ● Clear the dirt on the exterior of radiator and air intake;
Err16	Hardware Fault of Frequency inverter	In case of over-current or over-voltage existed in frequency inverter, it is judged as hardware fault	<ul style="list-style-type: none"> ● Handle as over-current and over-voltage fault;
Err17	Motor-to-ground short circuit	Motor-to-ground short circuit	<ul style="list-style-type: none"> ● Check whether the output line or motor of the frequency inverter has ground short circuit;
Err18	Motor Identification Error	When conducting the parameter identification, the fault occurs in motor	<ul style="list-style-type: none"> ● Check whether the motor parameter is consistent with the nameplate of the motor; ● Whether the frequency inverter and main cable of the motor are connected well;
Err19	Motor Off-load	Refer to the value of running current less than off-load current P6.1.19 and duration of P6.1.20	<ul style="list-style-type: none"> ● Check whether the load separates; ● Check whether the value set by Parameter P6.1.19 and P6.1.20;
Err20	PID Feedback Loss	Refer to the value of PID feedback value less than value of P4.0.18 and duration of P4.0.19	<ul style="list-style-type: none"> ● Check whether PID Feedback Signal is normal; ● Check whether the value set by Parameter P4.0.18 and P4.0.19 meets actual running conditions;

Chapter IX Fault Handling

Fault display	Description	Details	Fault elimination
Errr21	User-Defined Fault 1	Fault 1 Signal given by the users through multi-functional terminals or PLC Programming Function	<ul style="list-style-type: none"> ● Check whether the User-Defined Fault 1 is removed and then run after reset;
Errr22	User-Defined Fault 2	Fault 2 Signal given by the users through multi-functional terminals or PLC Programming Function	<ul style="list-style-type: none"> ● Check whether the User-Defined Fault 2 is removed and then run after reset;
Errr23	Accumulative Power-on Time Reached	Refer to the time given by accumulative power-on time arrival P5.1.01 of the frequency inverter	<ul style="list-style-type: none"> ● Use the parameter initialization function to clear the record information;
Errr24	Accumulative Running Time Reached	Refer to the time given by accumulative power-on time arrival P5.1.00 of the frequency inverter	<ul style="list-style-type: none"> ● Use the parameter initialization function to clear the record information;
Errr25	Encoder Fault	The frequency inverter is unable to identify the data of the encoder	<ul style="list-style-type: none"> ● Check whether the type of the encoder matches; ● Check whether the wiring connection of the encoder is correct; ● Check whether the encoder or PG card is damaged;
Errr26	Parameter Read-Write Abnormity	Damage of EEPROM Chip	<ul style="list-style-type: none"> ● Change main control panel;
Errr27	Motor Overheat	Detection on excessive temperature of the motor	<ul style="list-style-type: none"> ● Check whether the temperature of the motor is too high; ● Check whether the temperature sensor is damaged or its wirings are loose;
Errr28	Larger Speed Deviation	Refer to the value of speed deviation larger than P6.1.23 and duration of P6.1.24	<ul style="list-style-type: none"> ● Check whether the parameters of the encoder is set correctly; ● Check whether P6.123 and P6.124 are set rationally; ● Check whether the motor parameter identification has been conducted;
Errr29	Motor Over-speed	Refer to the value of motor speed over P6.1.21 and duration of P6.1.22	<ul style="list-style-type: none"> ● Check whether the parameters of the encoder is set correctly; ● Check whether P6.1.21 and P6.1.22 are set rationally; ● Check whether the motor parameter identification has been conducted;
Errr30	Initial Position Error	Large deviation between motor parameters and actual parameters	<ul style="list-style-type: none"> ● Check whether the motor parameters are correct, especially for rated current of the motor;
Errr31	Current Detection Fault	Circuit fault after current detection	<ul style="list-style-type: none"> ● Check whether the Hall device has defaults; ● Check whether the circuit has fault after detection of the driver board; ● Check whether the driver board has fault;

Chapter IX Fault Handling

Fault display	Description	Details	Fault elimination
Err32	Contactor	Abnormal power supply of driver board caused by the fault of the contactor	<ul style="list-style-type: none"> ● Check whether the contactor is normal; ● Check whether the power supply of the driver board is normal;
Err33	Abnormity of Current Detection	Circuit fault after current detection leads to abnormal current detection value	<ul style="list-style-type: none"> ● Check whether the Hall device has defaults; ● Check whether the circuit has fault after detection of the driver board; ● Check whether the driver board has fault;
Err34	Fast Current-limiting Timeout	The running current of the frequency inverter continues to be larger, which exceeds allowable current–limit time	<ul style="list-style-type: none"> ● Check whether the load is too large or is stalled; ● Check whether the size of the frequency inverter is too small;
Err35	Motor Switch at Running	Conduct motor switch in the running process of the frequency inverter	<ul style="list-style-type: none"> ● Conduct the switch operation of the motor after shutdown of the frequency inverter;
Err36	Power Fault	External 24V power supply is short circuit or the load of External 24V power supply is too large	<ul style="list-style-type: none"> ● Check whether external 24V power supply is short circuit; ● Reduce the load of external 24V power supply;
Err37	Driving Power Supply Fault	Driving Power Supply Fault for Model G250T4 and above	<ul style="list-style-type: none"> ● Check whether driving power supply in driver board is normal;
Err38	Output short circuit	3-phase output inter-phase short circuit	<ul style="list-style-type: none"> ● Check insulation of motor wire and motor;
Err40	Buffer Resistance	The Bus line voltage fluctuates strongly	<ul style="list-style-type: none"> ● Check whether the contactor is normal; ● Check the fluctuations of incoming voltage;

Note: Functional Introduction to PV Water Pump

A. Sleep Function (Err60)

While PV water pump is running, the frequency converter will enter sleep mode and display keyboard warning “Err60” when DC voltage provided by solar panel is lower than P6.2.11 (threshold of sleep voltage); when DC voltage of solar panel is recovered to P6.2.12 (sleep recovery voltage) point, it will start counting and after the P6.2.13 period (sleep shutdown wait period) is completed, the frequency converter will start running.

B. Low-frequency Protection Function (Err61)

PV water pump will enter protection standby status and display keyboard warning “Err61” if output frequency is lower than P6.2.14 (low-frequency protection detection frequency) and lasts for P6.2.15 period (low-frequency protection detection period) while PV water pump is running; when protection standby status is entered, it will recover auto running after the P6.2.16 period (auto recovery period of low-frequency protection) is completed.

C. Drying Protection Function (Err62)

Chapter IX Fault Handling

PV water pump will enter protection standby status and display keyboard warning “Err62” if its current output is lower than P6.2.17 (drying protection detection current) and the period last for P6.2.18 (drying protection detection time) while PV water pump is running; when protection standby status is entered, it will recover auto running after the P6.2.19 period (auto recovery period of drying protection) period is completed.

D. Overcurrent Protection Function (Err63)

PV water pump will enter protection standby status and display keyboard warning Err63” if its output current is greater than P6.2.20 (overcurrent protection detection current) and the period lasts for P6.2.21 (overcurrent protection detection time) while PV water pump is running; when protection standby status is entered, it will recover auto running after the P6.2.22 period (auto recovery period of overcurrent protection) is completed.

E. Min. Power Protection Function (Err64)

PV water pump will enter protection standby status and display keyboard warning “Err64” when output power is lower than P6.2.23 (min. power protection value) and the period lasts for P6.2.24 (min. power protection detection time) while PV water pump is running; when protection standby status is entered, it will recover auto running at the P6.2.25 period (auto recovery period of min. power) is completed.

F. Full Water Protection Function (Err65)

The full water alarm level and low level are detected by Terminal DI4 to realize auto control over water level; in which, P6.2.27 is detection time of full water protection, P6.2.28 is quit time of full water protection, Terminal DI4 is input of PV full water detection alarm signal, and its warning signal is “Err65”.

G. Alarm recovery mode: 0: Auto recovery; 1: Manual recovery

This item applies to the low-frequency protection function, drying protection function, overcurrent protection function and min. power function: The alarm recovery mode can be selected through P6.2.26. If it is selected as 0, the operator can press “STOP” key to shut down during auto recovery and fault display period; if it is selected as 1, the operator can press “STOP” key to clear manually during fault warning display, to realize shutdown.

H. PQ Curve Function

As this model supports customized PQ curve, so the user can set 5 groups of PQ points based on the conditions of water pump, in order to realize real-time calculation of flow speed, daily flow, accumulative flow, daily generating capacity and accumulated generating capacity; by default, the daily flow and daily generating capacity is calculated based on 7h per day.

I. Status Check

When PV water pump enters running status, the current running condition can be confirmed by checking P6.2.0

Appendix 1 Recommended Configuration of Solar Cell Modules

Product Model	Open-circuit Voltage Class of Solar Cell Module			
	37±1V		45±1V	
	Module Power ±5 Wp	Number of each string of modules * number of strings	Module power ±5 Wp	Number of each string of modules * number of strings
CDI-SPDG0R4SS2	250	11*1	300	9*1
CDI-SPDG0R7SS2	250	11*1	300	9*1
CDI-SPDG1R5SS2	250	11*1	300	9*1
CDI-SPDG2R2SS2	250	11*1	300	9*1
CDI-SPDG4R0SS2	250	11*2	300	9*2
CDI-SPDG5R5SS2	250	11*3	300	9*3
CDI-SPDG0R4S2	250	11*1	300	9*1
CDI-SPDG0R7S2	250	11*1	300	9*1
CDI-SPDG1R5S2	250	11*1	300	9*1
CDI-SPDG2R2S2	250	11*1	300	9*1
CDI-SPDG4R0S2	250	11*2	300	9*2
CDI-SPDG5R5S2	250	11*3	300	9*3
CDI-SPDG4R0T2	250	11*2	300	9*2
CDI-SPDG5R5T2	250	11*3	300	11*3
CDI-SPDG0R7T4	250	18*1	300	15*1
CDI-SPDG1R5T4	250	18*1	300	15*1
CDI-SPDG2R2T4	250	18*1	300	15*1
CDI-SPDG4R0T4	250	20*1	300	16*1
CDI-SPDG5R5T4	250	18*2	300	15*2
CDI-SPDG7R5T4	250	18*2	300	15*2
CDI-SPDG011T4	250	18*3	300	15*3
CDI-SPDG015T4	250	18*4	300	15*4
CDI-SPDG018.5T4	250	18*5	300	15*5
CDI-SPDG022T4	250	18*6	300	15*6
CDI-SPDG030T4	250	18*8	300	15*8
CDI-SPDG037T4	250	18*10	300	15*10
CDI-SPDG045T4	250	18*12	300	15*12
CDI-SPDG055T4	250	18*15	300	15*15
CDI-SPDG075T4	250	18*20	300	15*20
CDI-SPDG090T4	250	18*25	300	15*25
CDI-SPDG110T4	250	18*30	300	15*30
CDI-SPDG132T4	250	18*36	300	15*36
CDI-SPDG160T4	250	18*43	300	15*43
CDI-SPDG185T4	250	18*50	300	15*50
CDI-SPDG200T4	250	18*55	300	15*55
CDI-SPDG220T4	250	18*60	300	15*60
CDI-SPDG250T4	250	18*67	300	15*67
CDI-SPDG280T4	250	18*75	300	15*75
CDI-SPDG315T4	250	18*84	300	15*84
CDI-SPDG350T4	250	18*94	300	15*94
CDI-SPDG375T4	250	18*100	300	15*100
CDI-SPDG400T4	250	18*107	300	15*107

Annex 2 AC/DC Switch Scheme of Frequency Converter

DC and AC access of frequency converter at the same time is forbidden under general circumstance. If AC/DC access at the same time is required, a switch control circuit needs configuring externally. The following two schemes are provided for reference in order to realize working all day long:

A2.1 AC/DC automatic switch module

The EM60-PL expansion module and E102-PL expansion module are products developed for photovoltaic water pump frequency converters to achieve automatic AC/DC switching. Low-voltage components must be configured.

EM60-PL Expansion Module Wiring Diagram:

The EM60 control board includes an expansion interface. Therefore, the EM60-PL expansion module connects via the expansion interface on the EM60 control board.

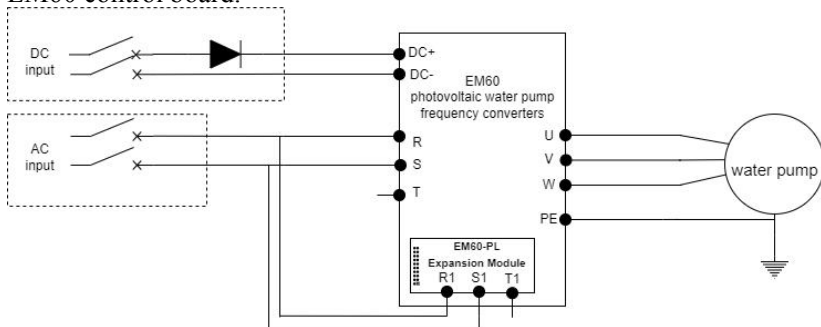

Descriptions of switching module terminal:

Terminal Symbol	Terminal	Terminal Description
DC+	Photovoltaic input	Connected to positive pole of voltage detection board, positive pole of diode module
DC-	Photovoltaic output	Connected to negative pole of voltage detection board, negative pole of diode module
R1,S1,T1	AC Power Input (Expansion Module)	Connect to AC power supply: 3-phase 380V or 2-phase 220V.
R,S,T	AC Power Input (Controller Driver)	Connect to AC power supply: 3-phase 380V or 2-phase 220V.

E102-PL Expansion Module Wiring Diagram:

The E102 control board does not have an expansion interface. Therefore, the E102-PL expansion module requires a connection cable to link digital signals to the DI6 port on the control board.

Appendix 1 Recommended Configuration of Solar Cell Modules

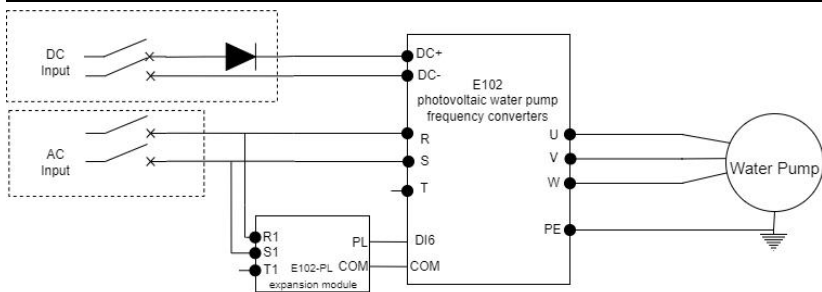

Terminal Descriptions for E102-PL Expansion Module:

Terminal Symbol	Terminal	Terminal Description
DC+	Photovoltaic input	Connected to positive pole of voltage detection board, positive pole of diode module
DC-	Photovoltaic output	Connected to negative pole of voltage detection board, negative pole of diode module
R1,S1,T1	AC Power Input (Expansion Module)	Connect to AC power supply: 3-phase 380V or 2-phase 220V.
R,S,T	AC Power Input (Controller Driver)	Connect to AC power supply: 3-phase 380V or 2-phase 220V.
PL,COM	Switch Signal Input	Switch signal input. Connect to the DI6 and COM ports.

Note: Ensure proper configuration of low-voltage components and verify compatibility before operation.

Installation size:

EM60-PL Expansion Module Installation Dimensions:

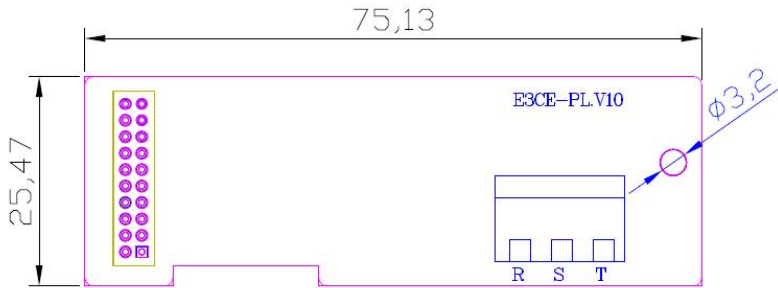

E102-PL Expansion Module Installation Dimensions:

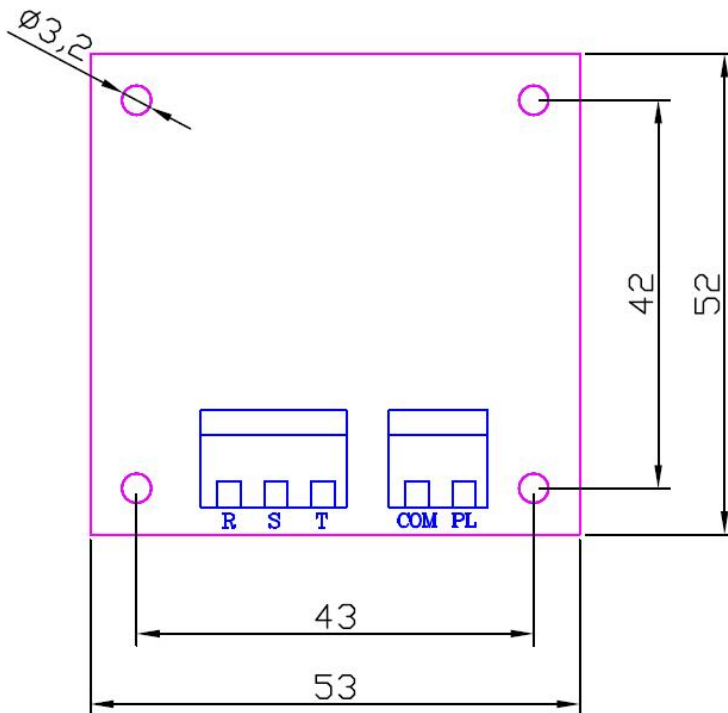

A2.2 AC/DC manual switch scheme

The frequency converter cannot run at a high frequency when the DC voltage at PV input end is low. Therefore, AC power needs accessing to ensure running at a rated frequency. Improper operation may lead to damage of frequency converter. To ensure the correct use of frequency converter, please operate according to the following method if AC/DC automatic switch module is not used:

If AC power is accessed for frequency converter, stop running the converter manually and do not access AC power until RUN indicator is off. Run the frequency converter after motor stops.

Note: The scheme is applicable to the software version 201.36 and above. For the rest versions, power off the frequency converter and access DC and AC power in sequence after button indicator is off. (The two schemes entail anti-reverse connection diode at PV input end)

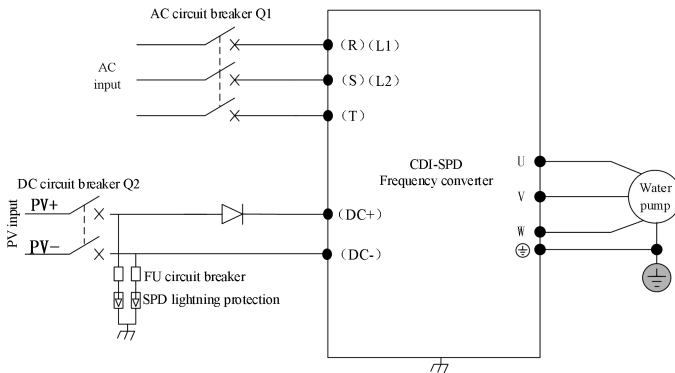

Low voltage electrical selection table:

Function Code	AC circuit breaker (A)	DC circuit breaker	AC contactor (A)	Lightning arrester	Fuse
CDI-SPDG0R4SS2	16	16A/1000VDC	16	Type II 1000VDC	30 A fast fuse
CDI-SPDG0R7SS2	16		16		
CDI-SPDG1R5SS2	25		25		
CDI-SPDG2R2SS2	40	25A/1000VDC	40		
CDI-SPDG4R0SS2	50	63A/1000VDC	50		
CDI-SPDG5R5SS2	63	100A/1000VDC	63		
CDI-SPDG0R4S2	16	16A/1000VDC	16		
CDI-SPDG0R7S2	16		16		
CDI-SPDG1R5S2	25		25		
CDI-SPDG2R2S2	40	25A/1000VDC	40		
CDI-SPDG4R0S2	50	63A/1000VDC	50		
CDI-SPDG5R5S2	63	100A/1000VDC	63		
CDI-SPDG4R0T2	25	25A/1000VDC	25		
CDI-SPDG5R5T2	40	63A/1000VDC	40		
CDI-SPDG0R7T4	10	16A/1000VDC	12		
CDI-SPDG1R5T4	10		12		
CDI-SPDG2R2T4	10		12		
CDI-SPDG4R0T4	25		25		
CDI-SPDG5R5T4	25	25A/1000VDC	25		
CDI-SPDG7R5T4	40		40		
CDI-SPDG011T4	50	63A/1000VDC	50		
CDI-SPDG015T4	63		63		
CDI-SPDG018.5T4	63	100A/1000VDC	63		
CDI-SPDG022T4	100		95		
CDI-SPDG030T4	100		95		
CDI-SPDG037T4	125	125A/1000VDC	115		

Appendix 1 Recommended Configuration of Solar Cell Modules